

Guidelines for Inspecting EIFS Clad Homes

Master Builders Solutions provides the following guidelines as an aid to help inspectors, builders, relocation managers, realtors, and homeowners to better understand the importance of key details in relation to the performance of the walls of a home.

What are specifications and details?

Specifications are documents for architects, builders and applicators containing important written instructions on the proper use of construction products.

Specifications describe:

- Acceptable substrates over which the EIFS can be applied, such as plywood, OSB, gypsum sheathing, concrete block, Dens-Glass Gold, etc.;
- Components of the EIF system such as insulation board, Adhesives, Reinforcing Mesh, Base Coat, and Finish Coat;
- Basic application steps.
- Manufacturer's typical details are drawings showing how the EIFS should be terminated on a vertical wall at critical junctures such as at windows, above grade, where there are penetrations in the EIF system such as at dryer vents, faucets, lights, etc.

Typical details also show auxiliary products that are not part of the EIFS, but which should be installed to aid in the performance of the entire wall assembly. These auxiliaries include, but are not necessarily limited to: secondary weather barriers; sealants (popularly referred to as "caulking"); and flashing, which is typically the metal that is installed above and below windows, at roof lines, around chimneys, and at "kick-out" points (where the wall and roof intersect). In the case of exterior wall cladding systems, the objective of all these details and specifications is to maintain a water resistant exterior wall system. Master Builders Solutions' typical details are intended as conceptual interface details. It is the responsibility of project architects and/or designers to properly integrate all components of the wall assembly.

Details, although meaningful to construction professionals, might not be clear to all for whom this brochure is intended. For clarity in this document, we use isometric drawings to illustrate details.

In addition to the published Master Builders Solutions specifications and details, Master Builders Solutions has commonly provided additional guidance to address conditions that might fall outside the areas covered by information in the specs and details. We have technical field representatives, a toll free hotline (+1 (800) 589-1336), and an extensive web site (www.master-builders-solutions.com/en-us) where those who are interested can review technical information, frequently asked questions, or can contact us with specific requests.

When builders, general contractors, or applicators utilize alternative details, the alternative detail should be designed and installed to provide the required weather resistance and good performance.

Master Builders Solutions' typical details and specifications were developed to help ensure optimal performance of our systems. However, if certain details were not followed during construction, you should not assume that the integrity of the EIFS wall has been negatively affected or that actions are required. We favor a practical approach to recommendations that follow an inspection. Most importantly, before making unnecessary repairs, determine if the wall is performing as intended. This can be accomplished through inspection by a qualified individual. In most cases, if the wall is not performing as intended, it is possible to improve wall performance with effective and economical steps to address shortcomings.

Inspection reports noting variances from the manufacturer's current or prior details or specifications should not recommend corrections based upon assumptions that the variances are negatively affecting the wall assembly. Variances do not necessarily require corrections to the manufacturer's current standards. Inspectors should limit their recommendations to repairs that are necessary based on service condition, and are also effective and economical. Following are descriptions of some typical details, their intended purposes, and considerations that should be taken into account if the details were not executed exactly as suggested by the manufacturer.

DOWNSPOUT ATTACHMENT

Intended Purpose: Fasten downspout to “screwable” sheathing or wood blocking in a manner to help prevent water intrusion into the EIFS through fastener penetrations.

Considerations: In many instances the fasteners used to attach the downspout straps were not installed through the appropriate sleeve with sealant. In order to prevent water intrusion into the EIFS, sealant needs to be applied over all fastener heads. It is not necessary to remove the fastener and downspout straps to install the sleeve with sealant.

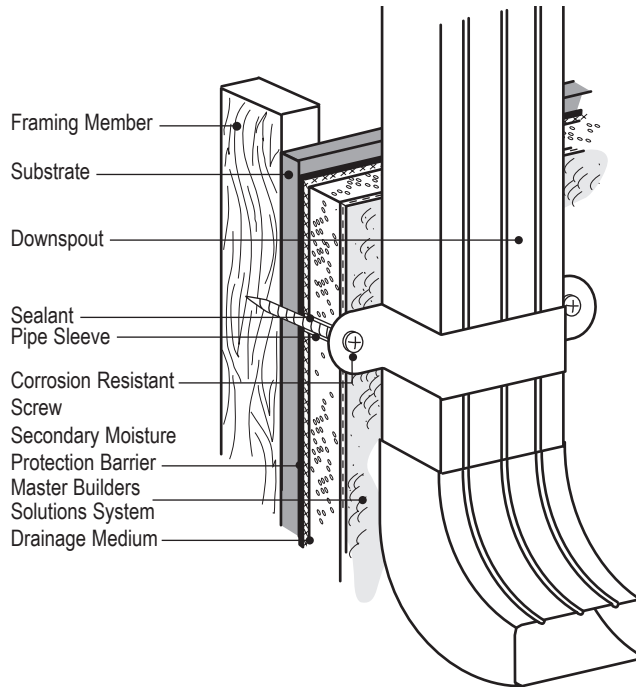

SHUTTER ATTACHMENT

Intended Purpose: Install shutter to “screwable” sheathing or wood blocking in a manner to help prevent water intrusion into the EIFS through fastener penetrations.

Considerations: In many instances the fasteners used to attach the shutter were not installed through the appropriate sleeve with sealant. If the existing shutters are not adequately secured and or sealed, the shutters should be removed and the appropriate sleeve with sealant installed prior to the shutters being reattached.

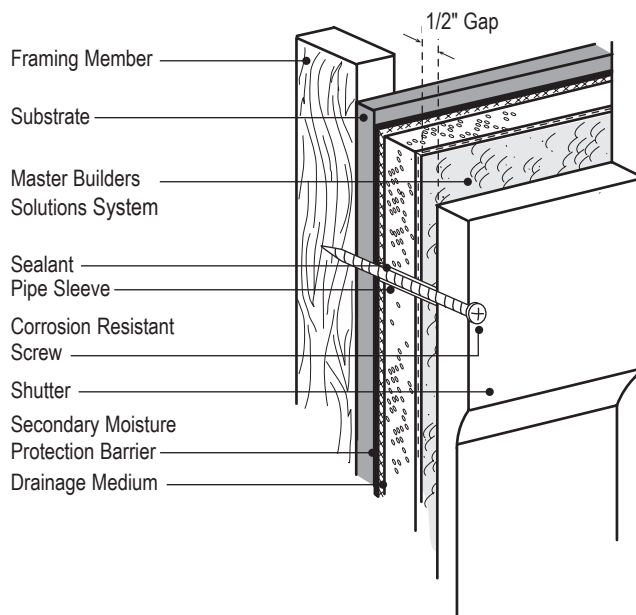

HORIZONTAL JOINT AT FLOOR LINE (NOT ILLUSTRATED)

Intended Purpose: Standard lumber used for framing homes can shrink as it dries. When shrinkage of the perimeter floor joists occurs after EIFS are applied, the result might be a bulging of the wall, compression cracks, and/or potential weakening of the attachment of the EIFS to the sheathing under it. To accommodate this moisture-based "cross grain" shrinkage, Master Builders Solutions details depict a break in the EIFS over the potential shrinkage area. This joint is small, typically a 3/4 inch space which receives backer rod and sealant and can be hidden from view by the clever use of integral shapes or bands.

Considerations: It is common to find that the horizontal joint was not installed, yet no problem has occurred several years after construction. Lumber that was kept dry during storage prior to construction will not shrink noticeably. Many builders are also now using composite type framing members that do not shrink and therefore do not require installation of a horizontal joint.

In any case, if there is no visible problem, there should be no attempt to add this horizontal floor line joint to a finished home. To do so would be an unnecessary and costly expense.

SEALANT JOINTS AROUND OPENINGS AND PENETRATIONS

Intended purpose: Prevent water intrusion between the EIFS and adjacent walls, windows, doors and other penetrations.

Considerations: Using the sealants recommended by Master Builders Solutions in the manner which is prescribed by the sealant manufacturers and Master Builders Solutions will prevent water from entering the wall at these intersections. Sealants that do not perform as required might limit the degree of protection that the prescribed approach would have provided.

If a space around the window was not provided, and if the window extends out past the EIFS, then a bond breaker and fillet bead of sealant is an effective seal. In such cases, it is not necessary to cut the EIFS back from the window so that backer rod and sealant can be applied.

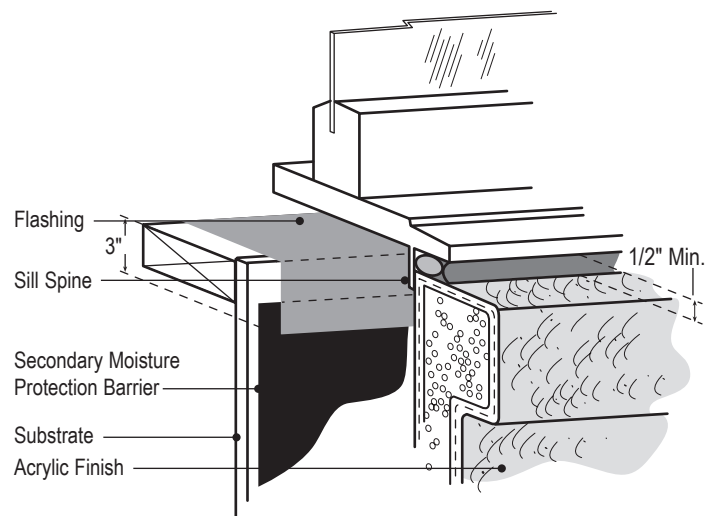
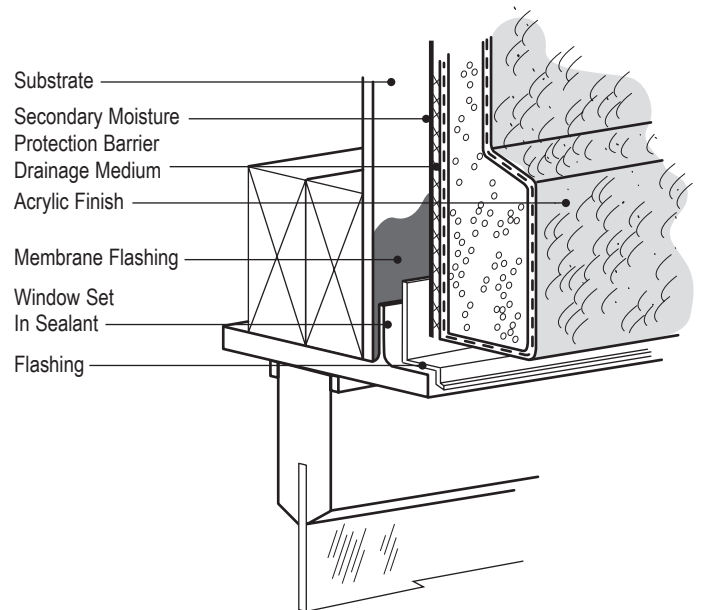

**KICK-OUT/DIVERTER AT
 ROOF/WALL INTERSECTION**

Intended Purpose: Accumulating water runoff should be directed out and away from the structure. Roof-to-wall flashing requires a kick-out/ diverter at its termination to insure that water is directed to the outside.

Considerations: The diverter can vary in its dimensions to accommodate local exposure conditions and specific detailing requirements, as long as it directs water completely away from wall surfaces.

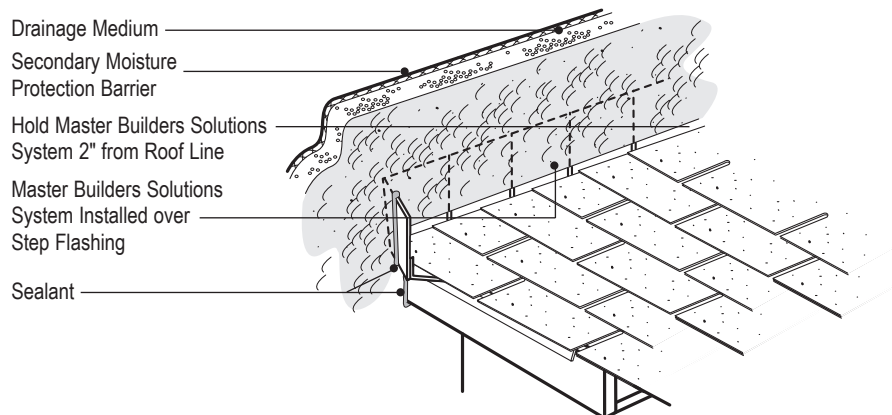
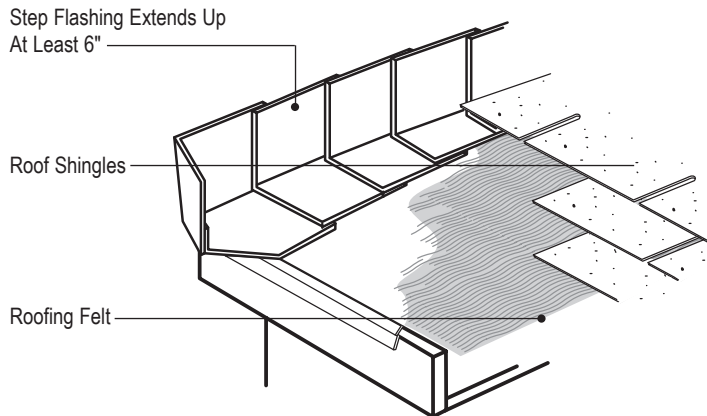
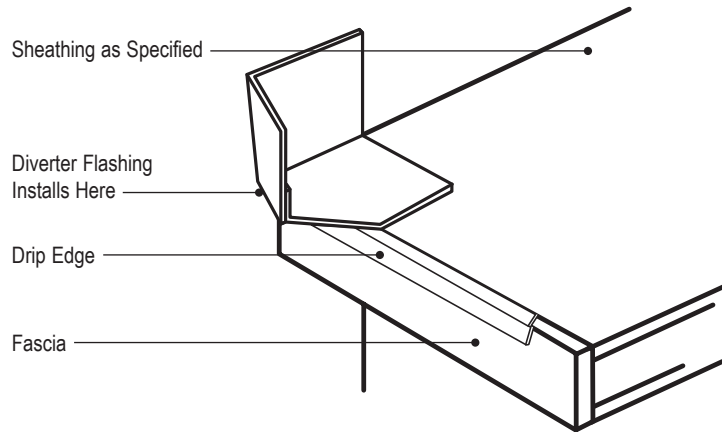

TERMINATION ABOVE FINISHED GRADE

Intended Purpose: The EIFS should be terminated a minimum of 8 inches above grade in order to allow access for visual inspection and treatment of the foundation for pest control.

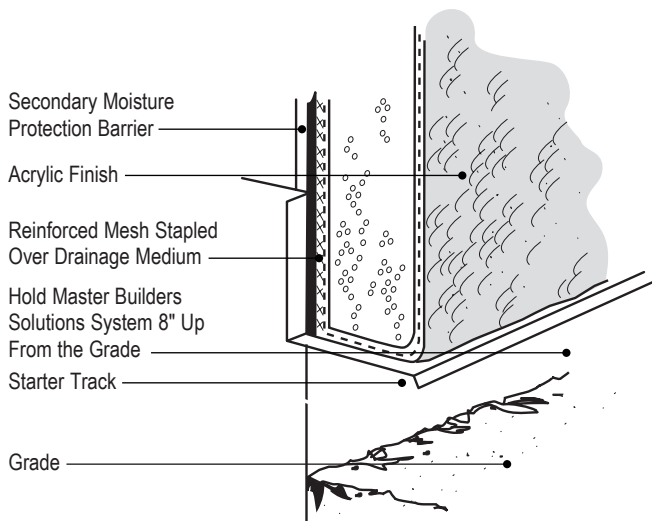
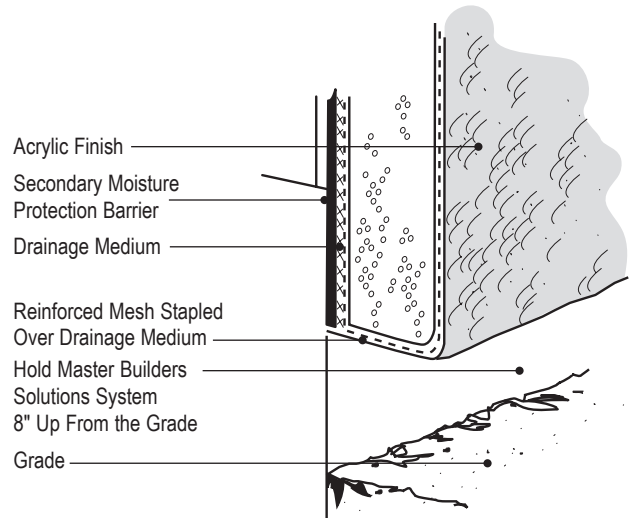

Considerations: Although Master Builders Solutions specifications and details have never suggested running the system to grade or below grade, the Department of Energy originally recommended running insulation below grade. This did not become an issue with pest control companies until the Environmental Protection Agency outlawed the pesticide, chlordane. Now, without a strong and lasting termiticide, the pest control companies often need to visually inspect the base of the wall. This requires the use of the detail that Master Builders Solutions always showed.

TERMINATION ABOVE ROOF LINE OR DECK

Intended Purpose: A gap allows for appropriate system edge termination, ease of roof or deck replacement or repair. It also allows for the system and flashing to be inspected for proper installation.

Considerations: On an existing project, the termination can occur closer to the roof or deck surfaces than indicated in published details without harm, as long as the bottom edge of the EIFS conforms to our requirements.

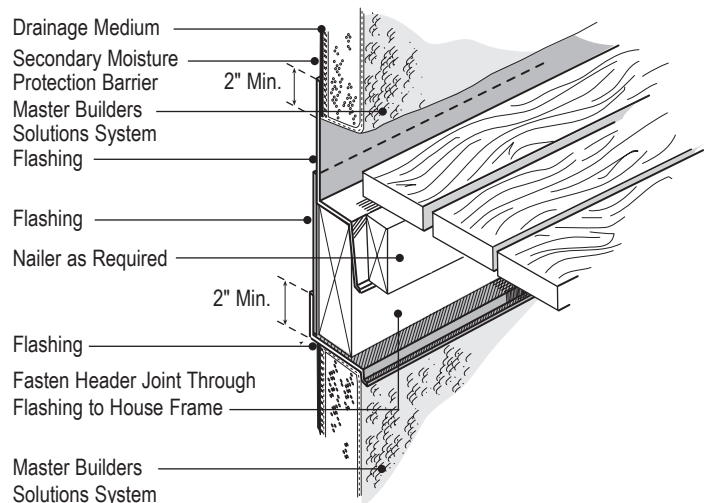

CHIMNEY, FLASHING AND CRICKETS

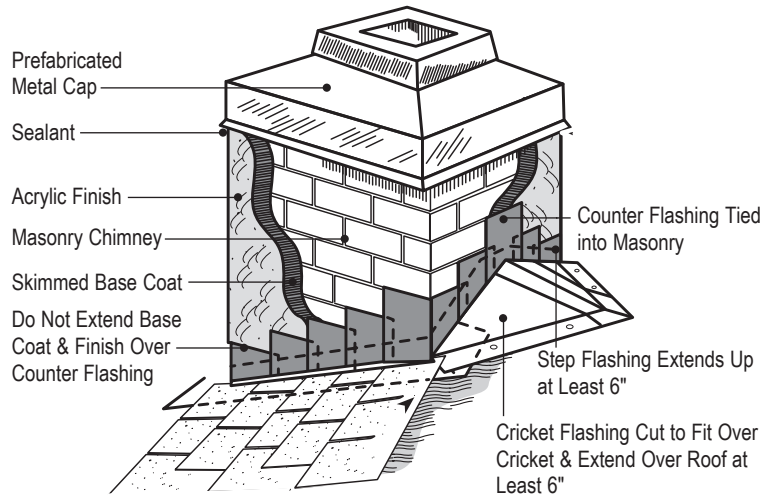
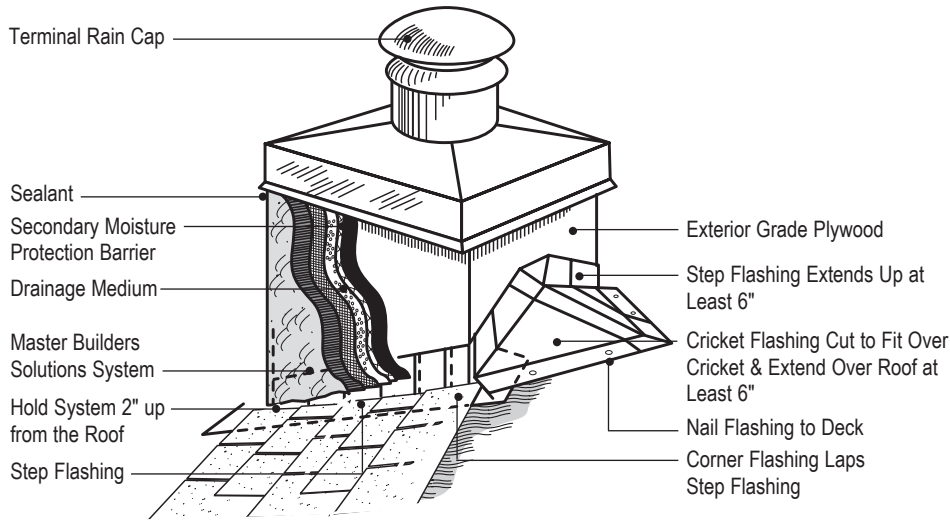

MINIMUM 6:12 SLOPED SURFACES (NOT ILLUSTRATED)

Intended Purpose: Reduce the potential for accumulation of snow and sitting water that could soften the finish.

Considerations: Horizontal surfaces are not desirable because they could be more susceptible to freeze/thaw damage. However, if the horizontal projection off the vertical surface extends only an inch, or if the building is located in an arid and/or a mild climate, there is little likelihood of damage.

If signs of damage are noted, apply two coats of an elastomeric to the horizontal surface, or apply a fillet bead of sealant along the junction of the band or other projection and the wall.

If a wider horizontal section of EIFS exists such as at parapet caps, it should be fitted with flashing that covers the entire horizontal surface and extends a minimum of two inches over the vertical edge.

GABLE AND SOFFIT END TERMINATION

Intended Purpose: The EIFS should be terminated in a manner to help prevent water from entering between the EIFS and the wall to roof assembly.

Considerations: In some cases the EIFS may have been applied tight against the soffit/gable end. In areas where this occurs, a triangular backer rod with sealant can be installed to help prevent water from entering the EIFS. It is not necessary to cut the EIFS back in order to make room for backer rod and sealant.

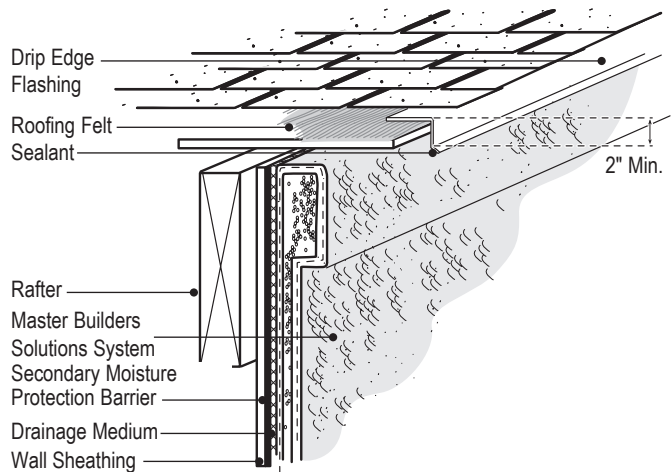
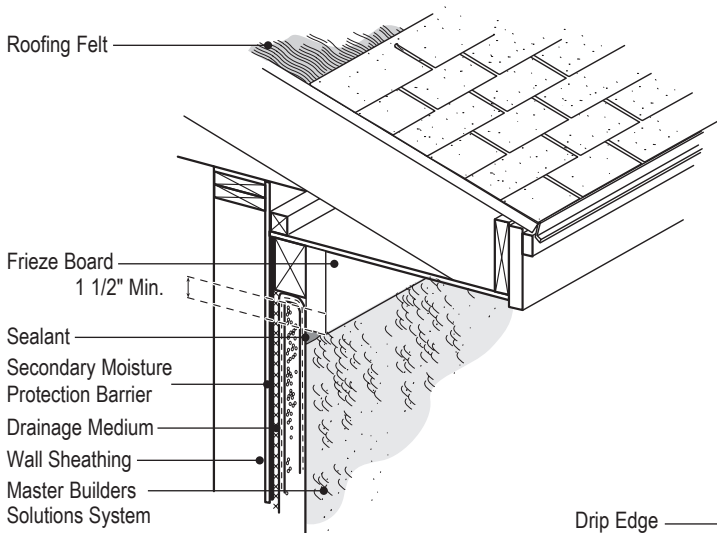
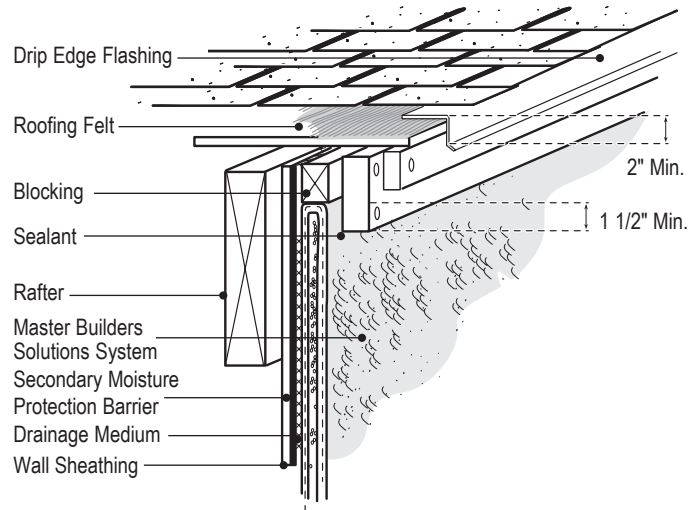

For the most current version of this literature, please visit our website at www.master-builders-solutions.com/en-us.