

Senergy Platinum CI Stucco Plus

A continuously insulated stucco system featuring Senersshield-R/-RS/-VB air/water-resistive barrier

DESCRIPTION

Senergy Platinum CI Stucco Plus is a continuously insulated stucco system provides a variety of rigid insulation board options to optimize thermal performance. Acceptable rigid insulation boards include EPS, Neopor, XPS and Polyiso for ease of design to ensure energy code compliance.

The system uses Senergy liquid applied air/water-resistive barriers provide a premium level of protection of the sheathing and cavity against moisture and air intrusion. Optional Senergy Base Coat and DiamondShield reinforcing mesh are available for superior crack suppression.

Senergy Platinum CI Stucco Plus offers design flexibility, aesthetic appeal and energy savings. Finishes are available in a limitless color selection. Performance enhancement options include increased resistance to dirt pick-up and mildew, and specialty finishes that create stone-like, metallic or mottled stucco appearances.

Senergy Platinum CI Stucco Plus has passed rigorous tests including Full-Scale Fire, Radiant Heat, Wind-Load, and Water Resistance. The system features easy installation, proven durability and low maintenance.

Apply the system directly to the following acceptable substrates:

- ASTM C1177 type sheathings, including DensGlass™ exterior sheathing, eXP™ sheathing, GlasRoc® sheathing, Securock™ glass-mat sheathing, Weather Defense™ Platinum sheathing, and GreenGlass® sheathing
- PermaBase™ cement-board by National Gypsum and other cement-boards (ASTM C1325 Type A Exterior)
- Untreated Exposure I or exterior plywood sheathing (grade C-D or better)
- Untreated Exposure I OSB
- Huber Zip Sheathing (sheathing only)
- Gypsum sheathing (ASTM C79/ASTM C1396)
- Poured concrete/unit masonry

USES

For exterior walls in new and retrofit commercial, institutional and residential construction when a continuous high effective R-value is needed to meet energy or eco-efficiency standards, and/or when a rainscreen is desired or required to satisfy code issues related to drainage.

ADVANTAGES

- Highly energy efficient, easy to specify a design that meets ASHRAE design standards and IGCC/IECC code requirements for the use of continuous insulation
- Provides a drainage plane for directing incidental moisture out of the wall assembly
- Fluid applied air/water-resistive barrier provides a durable, seamless secondary moisture protection
- Seamless wall surface provides high resistance to potential water intrusion from rain and other environmental sources
- Available PermaLath1000 self-furred glass fiber reinforcing lath that will not rust
- Factory prepared StuccoBase minimizes potential site mixing errors; improves quality control
- Senergy acrylic modified base coat over StuccoBase enhances water resistance performance and finish coat aesthetics
- Elastomeric finish coat bridges hairline cracks.
- DiamondShield reinforcing mesh option further increases crack resistance
- Resistant to impact and punctures; good for high traffic areas.
- Provides design flexibility with numerous design options
- Fade, abrasion and dirt-resistant
- Wide selection of finish textures, standard colors and unlimited custom colors

Senergy Platinum CI Stucco Plus System over metal studs

Senergy Platinum CI Stucco Plus System over wood studs

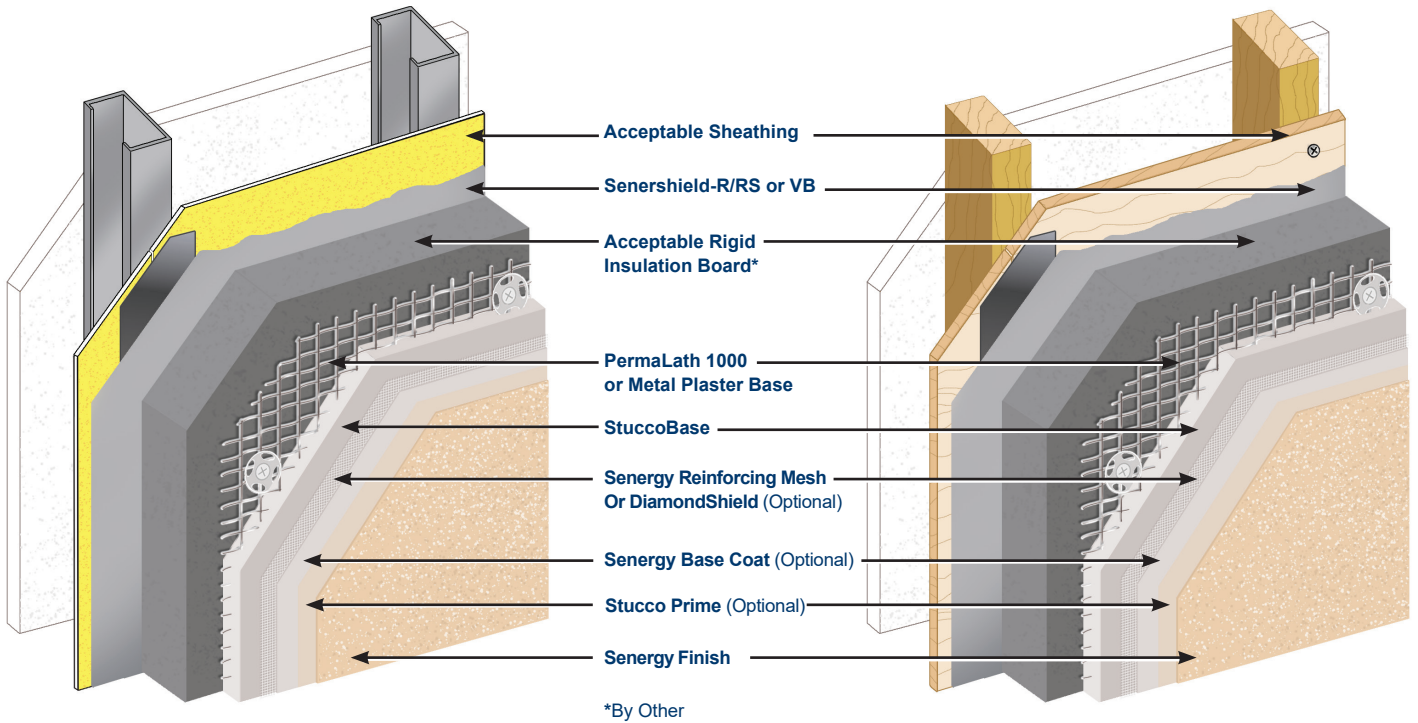

DESIGN CONSIDERATIONS

- Maximum allowable deflection $L/360$, based on structural properties only.
- The design wind load shall not exceed the system's allowable wind load as stated in applicable code reports.
- Details shall conform with Senergy Wall Systems recommendations and shall be consistent with the project requirements.
- Control joints and trim accessories required. Control joint placement is required in the Senergy Platinum CI Stucco Plus wall system every 144 ft² per ASTM C1063.
- Consult the framing and sheathing manufacturer for design and application considerations.
- Expansion joints are required in the system where they exist in the substrate, where the system adjoins dissimilar construction, at changes in substrates and at floor lines in multilevel wood frame construction.
- System shall terminate at expansion joints.
- Sealant joints shall be detailed and installed per sealant manufacturer's recommendations.
- A minimum 6:12 slope is required on all horizontal surfaces greater than 1".
- Backer rod, sealant and flashing are required at door and window openings.

Senergy Platinum CI Stucco Plus Test Results Complies with AC 11

TEST	RESULT
ASTM G153 Accelerated weathering	No deleterious effects after 2000 hours viewed under 5x magnification.
ASTM D2247 Water Resistance	No deleterious effects at 14 day exposure.
UBC Standard 26-9/NFPA 285 Intermediate Scale Multi-story Fire Test	Met test criteria
NFPA 268 Radiant heat exposure	Met test criteria
ASTM E 84 Surface burning	System Components Flame spread <25; Smoke developed <450
ASTM E119 Methods for fire tests of building construction and materials	1 hour rating with maximum R10 NEOPOR insulation
ASTM E136 Behavior of materials in a vertical tube furnace at 750° C	StuccoBase with PermaLath 1000 specimens met the weight loss criteria for passing the test.
ASTM E2273 Drainage efficiency	Exceeds 90% minimum
ASTM B117 Salt spray resistance	No deleterious effects at 300 hours exposure period.
AC11 Freeze-thaw resistance	No deleterious effects after 10 cycles viewed under 5x magnification.

Acceptable Rigid Insulation Boards (meet NFPA 285)

- Maximum 2.5-inch thickness of ASTM C578 Type II EPS must be ASTM E84 Class A)
 - Maximum 2.4-inch thickness NEOPOR GPS PLUS Type II Rigid Insulation Board
 - Maximum 3-inch thickness of ASTM C578 Type XI EPS (must be ASTM E84 Class A)
 - Maximum 1.7-inch thickness of ASTM C578 Type IX EPS must be ASTM E84 Class A)
 - Maximum 3-inch thickness XPS, ASTM C578 Type IV or Type X (must be ASTM E84 Class A)
 - Maximum 3-inch thickness, Atlas EnergyShield Pro
 - Maximum 3-inch thickness, Atlas EnergyShield Pro2
 - Maximum 3-inch thickness, Hunter Xci Class A
 - Maximum 3-inch thickness, Hunter Xci CG
 - Maximum 4-1/4-inch thickness, Hunter Xci Ply (maximum 3-1/2-inch foam, maximum 3/4-inch plywood)
 - Maximum 3-inch thickness, Carlisle R-2+ Sheathe, R2+ Mat or R2+ Silver
 - Maximum 3-inch thickness, unfaced noncombustible insulation (e.g. mineral wool)
- Note: Interior sheathing must be 5/8" type X gypsum wallboard for all CI Stucco systems

Master Builders Solutions
Constructions Systems US, LLC
889 Valley Park Drive
Shakopee, MN 55379 USA

Customer Service (800) 433-9517
Technical Service (800) 589-1336
senergy.master-builders-solutions.com/en



® registered trademark of a Group member
in many countries of the world

© 2021 MBCC Group, 170526 rev 04/2021

LIMITED WARRANTY NOTICE: Master Builders Solutions Construction Systems US, LLC ("Master Builders") warrants this product to be free from manufacturing defects and to meet the technical properties on the current Technical Data Guide, if used as directed within shelf life. Satisfactory results depend not only on quality products but also upon many factors beyond our control. Master Builders MAKES NO OTHER WARRANTY OR GUARANTEE, EXPRESS OR IMPLIED, INCLUDING WARRANTIES OF MERCHANTABILITY OR FITNESS FOR A PARTICULAR PURPOSE WITH RESPECT TO ITS PRODUCTS. The sole and exclusive remedy of Purchaser for any claim concerning this product, including but not limited to, claims alleging breach of warranty, negligence, strict liability or otherwise, is shipment to purchaser of product equal to the amount of product that fails to meet this warranty or refund of the original purchase price of product that fails to meet this warranty, at the sole option of Master Builders. Any claims concerning this product must be received in writing within one (1) year from the date of shipment and any claims not presented within that period are waived by Purchaser. Master Builders WILL NOT BE RESPONSIBLE FOR ANY SPECIAL, INCIDENTAL, CONSEQUENTIAL (INCLUDING LOST PROFITS) OR PUNITIVE DAMAGES OF ANY KIND.

Purchaser must determine the suitability of the products for the intended use and assumes all risks and liabilities in connection therewith. This information and all further technical advice are based on Master Builders present knowledge and experience. However, Master Builders assumes no liability for providing such information and advice including the extent to which such information and advice may relate to existing third party intellectual property rights, especially patent rights, nor shall any legal relationship be created by or arise from the provision of such information and advice. Master Builders reserves the right to make any changes according to technological progress or further developments. The Purchaser of the Product(s) must test the product(s) for suitability for the intended application and purpose before proceeding with a full application of the product(s). Performance of the product described herein should be verified by testing and carried out by qualified experts.