

Senergy[®]



Senerflex Vulcan NC System

Water Drainage Exterior Insulation and
Finish System Using Mineral Wool Insulation

Typical Details

BUILDING TRUST



Senerflex Vulcan NC System

Typical Details

Water Drainage Exterior Insulation and Finish System Using Mineral Wool Insulation

Table of Contents

- | | |
|---|---|
| 1. Mineral Wool Fastener Pattern | 15. Window Head (Flush) |
| 2. Application | 16. Window Head with Weep Tubes (Flush) |
| 3. Application over CMU | 17. Window Head (Recessed) |
| 4. Corner Mesh Application with Flexguard 4, Intermediate 6 or 12 | 18. Window Jamb (Flush) |
| 5. Pipe Penetration | 19. Window Sill (Flush) |
| 6. Light Fixture | 20. Window Jamb (Recessed) |
| 7. Expansion Joint | 21. Window Sill (Recessed) |
| 8. Expansion Joint at Change in Substrate | 22. Parapet Cap |
| 9. Expansion Joint at Floorline | 23. Kick-Out Flashing |
| 10. Drainage at Floorline | 24. Roof Edge Flashing |
| 11. EIFS Abutment to Brick with Drainage at Floorline | 25. Section at Fascia / Soffit |
| 12. EIFS Abutment to Brick with Continuous Drainage | 26. Core Mounted Railing Attachment |
| 13. Termination at Foundation | 27. Railing Attachment |
| 14. Termination at Foundation (Flush) | 28. Sign Attachment |

Notes:

- **The details within are the latest recommendations and are represent in good faith by Sika Corporation US (hereinafter Sika). The details are subject to change without notice. Sika accepts no liability for the end use of the details. For conditions not shown, consult Sika for review of specific details.**
- **Install Sika materials in accordance with current installation instructions.**
- **Unsatisfactory conditions shall be reported to the General Contractor and corrected before the application of Sika products.**

Senerflex Vulcan NC System

TYPICAL MINERAL WOOL FASTENER PATTERN

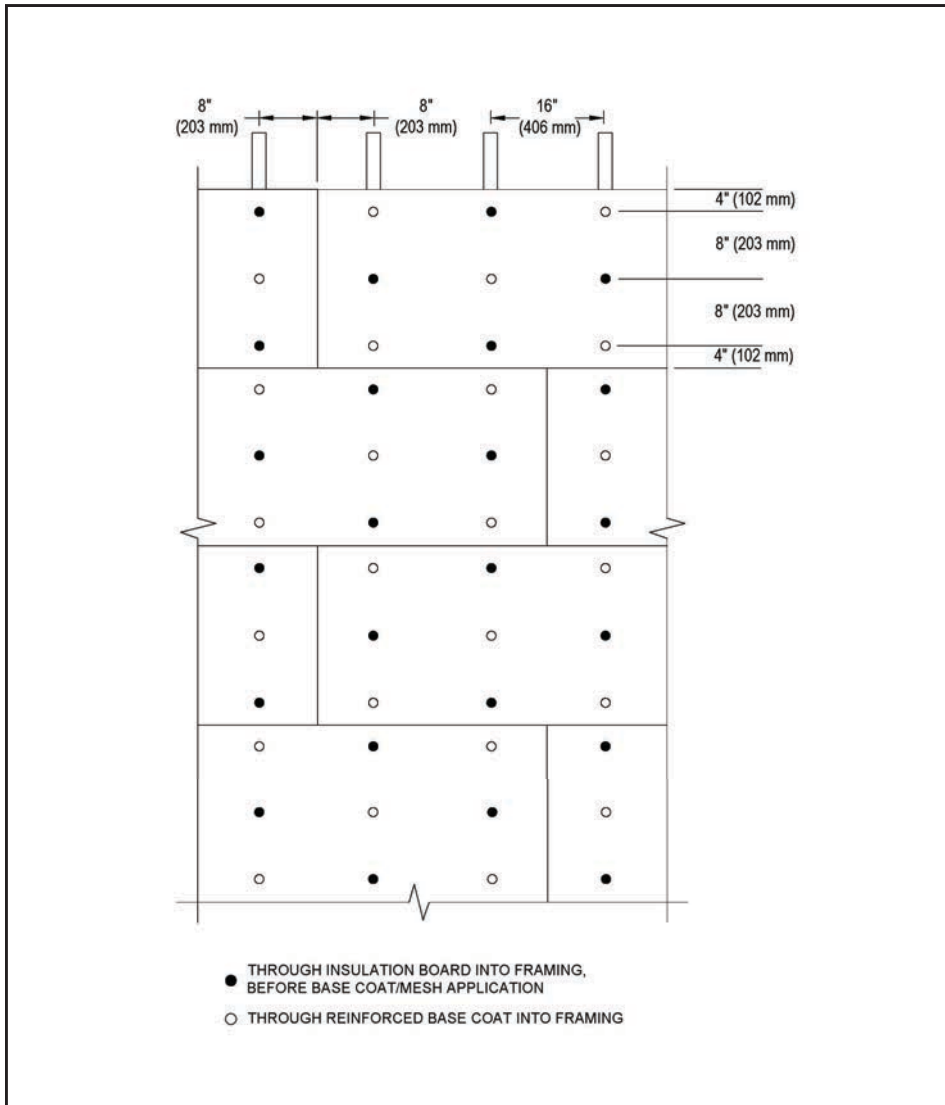

VNC-01 2401

(*NOTE: BY OTHERS)

The details within are the latest recommendations and are represented in good faith by Sika Corporation US (hereinafter Sika). The details are subject to change without notice. Sika accepts no liability for the end use of the details. For conditions not shown, consult Sika for review of specific details.

- Install Sika materials in accordance with current installation instructions.
- Unsatisfactory conditions shall be reported to the General Contractor and corrected before the application of Sika products.

- Additional fasteners may be required at corners or other terminations.
- Ensure a means for drainage is provided at System termination.
- Fasteners installed on the outside of the reinforced base coat should be spotted prior to application of final base coat.
- 9 fasteners per 2'x4' insulation board.
- Use Wind-Lock ULP-302 plates with fastener appropriate to insulation thickness and structure type.
- Allow adhesive to dry before installing fasteners.
- Install 4 fasteners per board after adhesive application of insulation board; install remaining 5 fasteners per board after the installation of reinforced base coat.
- Do not overdrive fasteners, washer should sit flush with face of insulation board/reinforced base coat or slightly (1/16") recessed.

Senerflex Vulcan NC System

TYPICAL APPLICATION

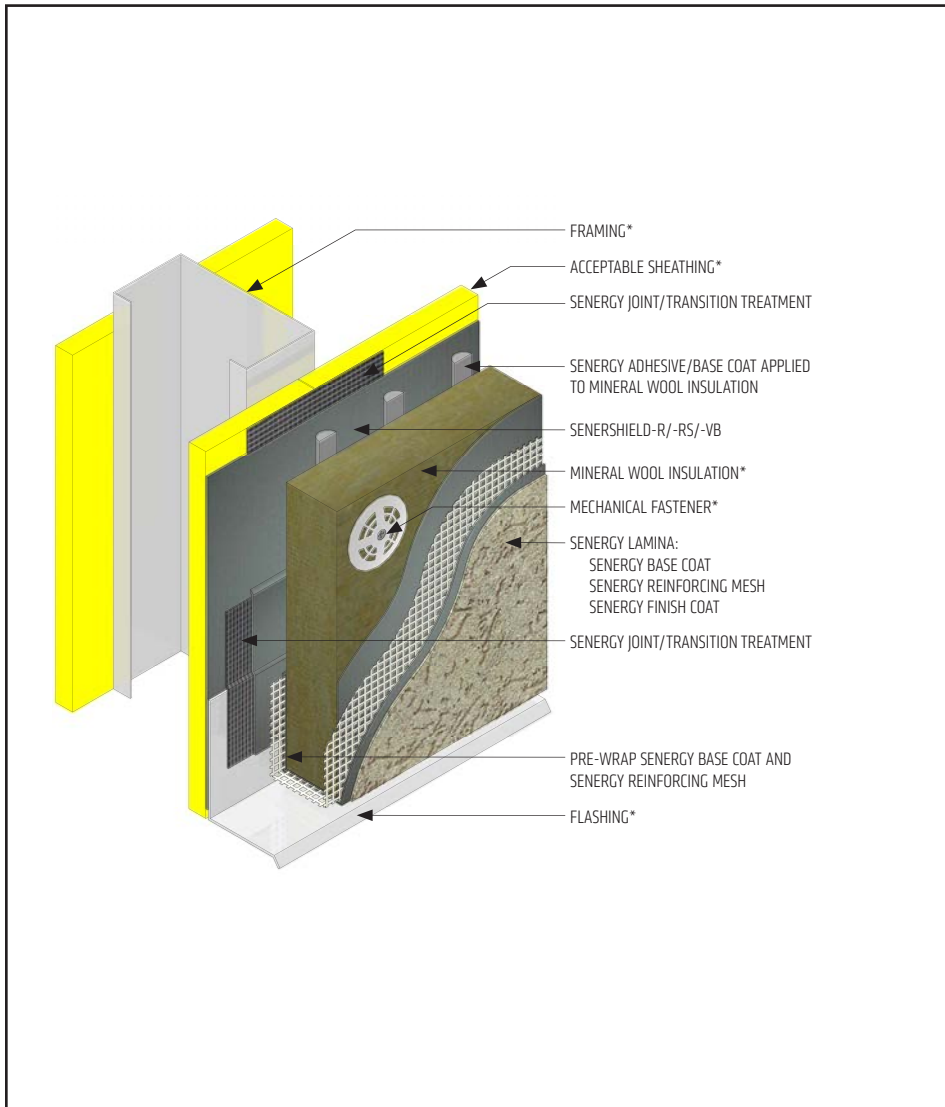

- All terminations must be fully encapsulated with mesh reinforced base coat. Pre-backwrapping is recommended at drainage terminations. Extend reinforcing mesh a minimum of 2 1/2" onto back of insulation board.
- Ensure a means for drainage is provided at system termination.
- Senergy Joint/Transition Treatment Options: SikaWall MaxFlash, SikaWall Sheathing Fabric embedded in Senershield-R/-RS/-VB or SikaWall Flash Seal NP.

VNC-02 2401

(*NOTE: BY OTHERS)

The details within are the latest recommendations and are represented in good faith by Sika Corporation US (hereinafter Sika). The details are subject to change without notice. Sika accepts no liability for the end use of the details. For conditions not shown, consult Sika for review of specific details.

- Install Sika materials in accordance with current installation instructions.
- Unsatisfactory conditions shall be reported to the General Contractor and corrected before the application of Sika products.

Senerflex Vulcan NC System

TYPICAL APPLICATION OVER CMU

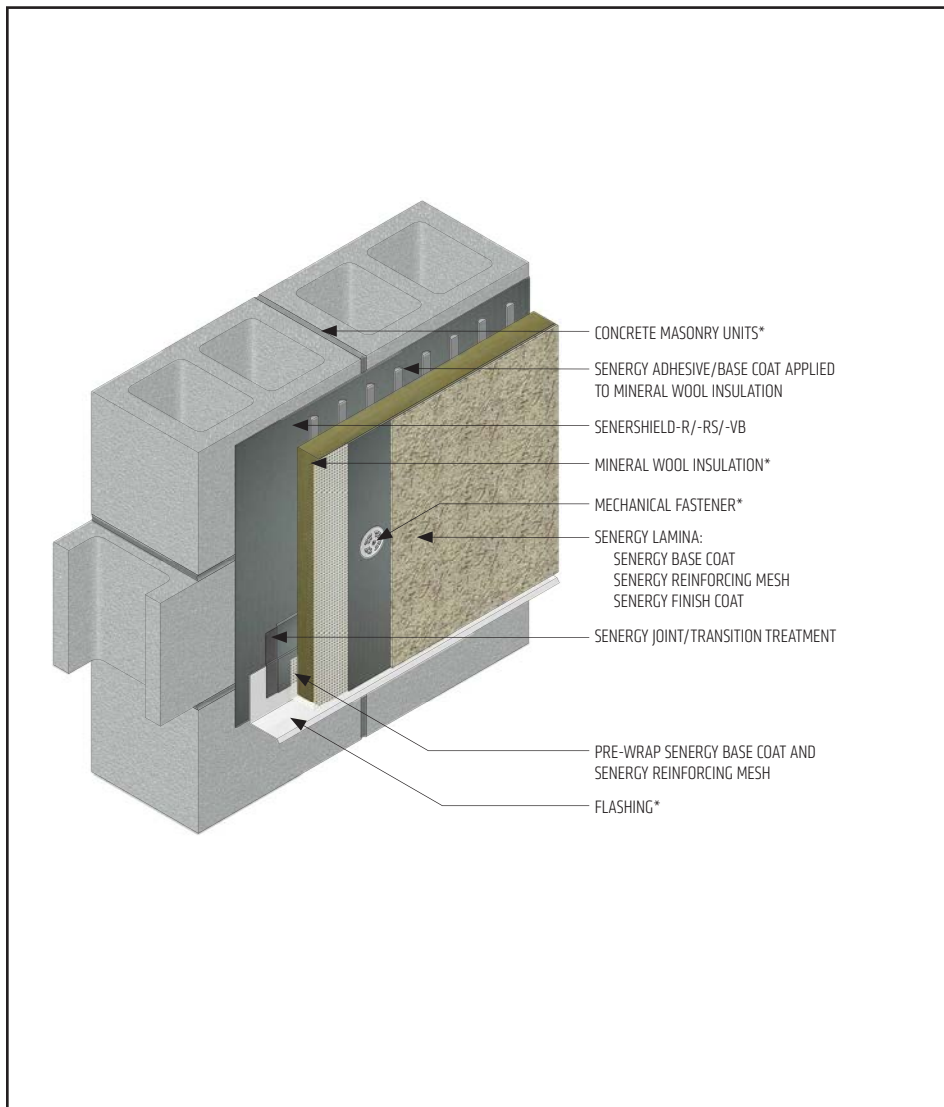

- All terminations must be fully encapsulated with mesh reinforced base coat. Pre-backwrapping is recommended at drainage terminations. Extend reinforcing mesh a minimum of 2 1/2" onto back of insulation board.
- Ensure a means for drainage is provided at System termination.

VNC-03 2401

(*NOTE: BY OTHERS)

The details within are the latest recommendations and are represented in good faith by Sika Corporation US (hereinafter Sika). The details are subject to change without notice. Sika accepts no liability for the end use of the details. For conditions not shown, consult Sika for review of specific details.

- Install Sika materials in accordance with current installation instructions.
- Unsatisfactory conditions shall be reported to the General Contractor and corrected before the application of Sika products.

Senerflex Vulcan NC System

TYPICAL CORNER MESH APPLICATION WITH FLEXGUARD 4, INTERMEDIATE 6 OR 12

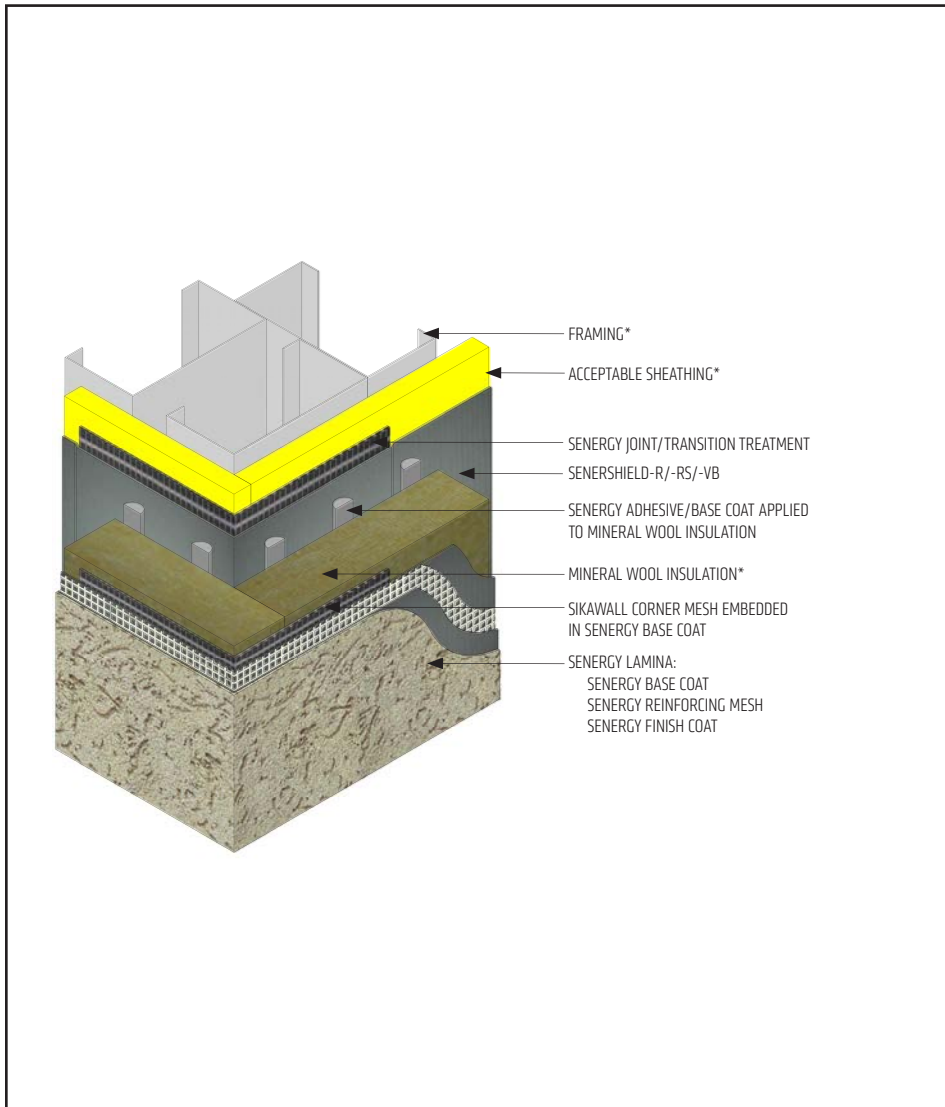

- SikaWall Corner Mesh on outside corner can be replaced, with Flexguard 4, SikaWall Intermediate 6 or Intermediate 12, extended a minimum of 8" (203 mm) around corner from both sides (creating double layer of mesh at the corner).
- Provide fasteners into structure at corners.
- Senergy Joint/Transition Treatment Options: SikaWall MaxFlash, SikaWall Sheathing Fabric embedded in Senershield-R/-RS/-VB or SikaWall Flash Seal NP.

VNC-04 2401

(*NOTE: BY OTHERS)

The details within are the latest recommendations and are represented in good faith by Sika Corporation US (hereinafter Sika). The details are subject to change without notice. Sika accepts no liability for the end use of the details. For conditions not shown, consult Sika for review of specific details.

- Install Sika materials in accordance with current installation instructions.
- Unsatisfactory conditions shall be reported to the General Contractor and corrected before the application of Sika products.

Senerflex Vulcan NC System

TYPICAL PIPE PENETRATION

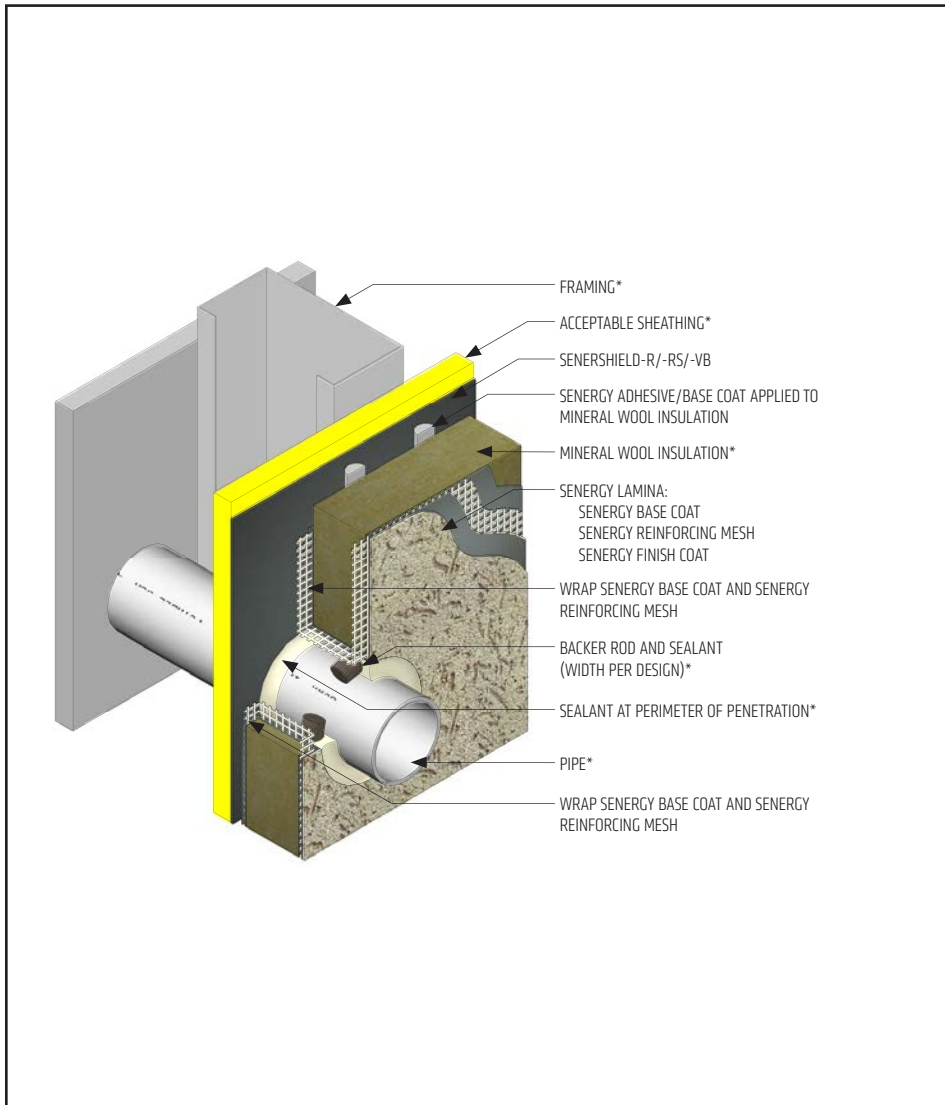

- All terminations must be fully encapsulated with mesh reinforced base coat. Extend reinforcing mesh a minimum of 2 1/2" onto back of insulation board.
- Ensure all penetrations into the system are properly sealed. Reference *Acceptable Sealants to use with Senergy Wall Systems* Technical Bulletin for a list of sealants.
- Provide continuous seal around perimeter of penetration prior to mineral wool insulation application. Reference *Acceptable Sealants for use with Senershield-R/-RS/-VB* Technical Bulletin for a list of sealants.
- Do not apply finish to areas that will receive sealant.

VNC-05 2401

(*NOTE: BY OTHERS)

The details within are the latest recommendations and are represented in good faith by Sika Corporation US (hereinafter Sika). The details are subject to change without notice. Sika accepts no liability for the end use of the details. For conditions not shown, consult Sika for review of specific details.

- Install Sika materials in accordance with current installation instructions.
- Unsatisfactory conditions shall be reported to the General Contractor and corrected before the application of Sika products.

Senerflex Vulcan NC System

TYPICAL LIGHT FIXTURE

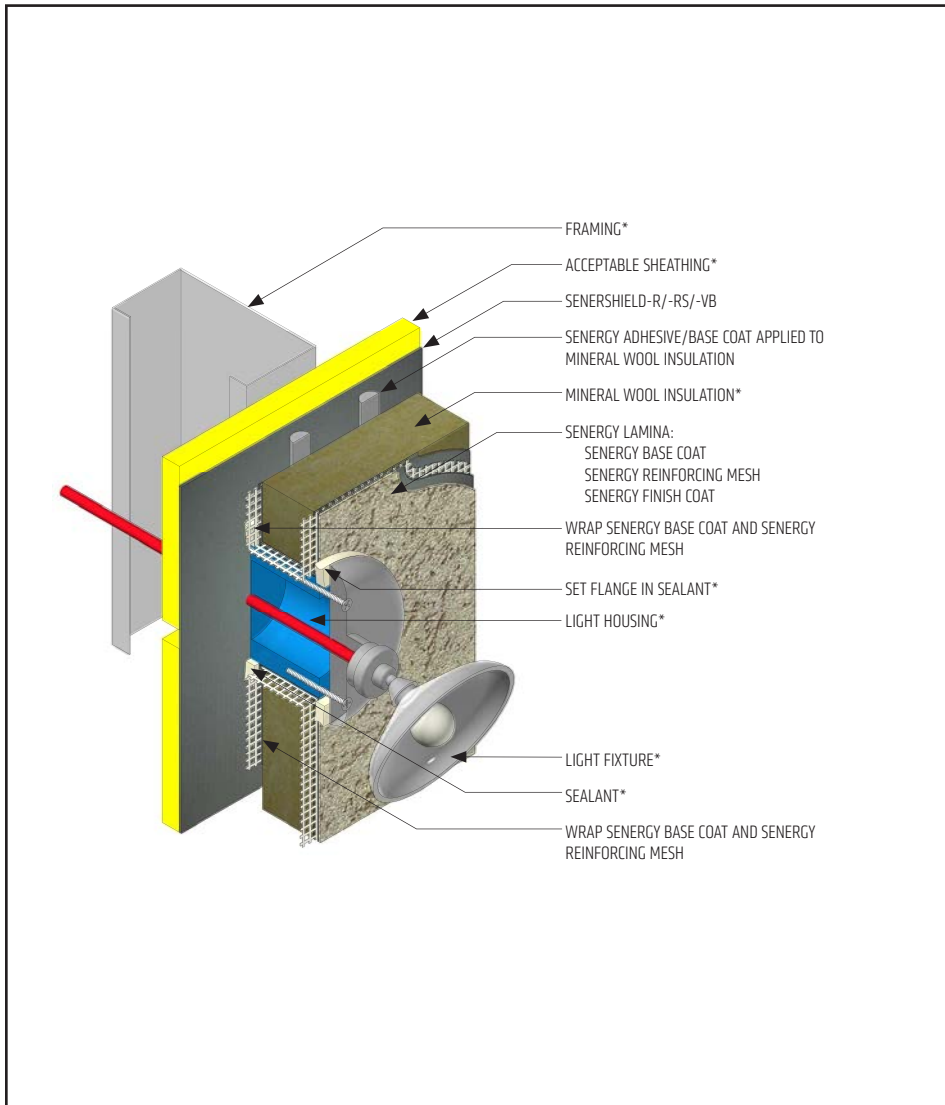

- All terminations must be fully encapsulated with mesh reinforced base coat. Extend reinforcing mesh a minimum of 2 1/2" onto back of insulation board.
- Ensure all penetrations into the system are properly sealed. Reference "Acceptable Sealants to use with Senergy Wall Systems" Technical Bulletin for a list of sealants.
- Provide continuous seal around perimeter of penetration prior to mineral wool insulation application. Reference *Acceptable Sealants for use with Senershield-R/-RS/-VB* Technical Bulletin for a list of sealants.
- Do not apply finish to areas that will receive sealant.

VNC-06 2401

(*NOTE: BY OTHERS)

The details within are the latest recommendations and are represented in good faith by Sika Corporation US (hereinafter Sika). The details are subject to change without notice. Sika accepts no liability for the end use of the details. For conditions not shown, consult Sika for review of specific details.

- Install Sika materials in accordance with current installation instructions.
- Unsatisfactory conditions shall be reported to the General Contractor and corrected before the application of Sika products.

Senerflex Vulcan NC System

TYPICAL EXPANSION JOINT

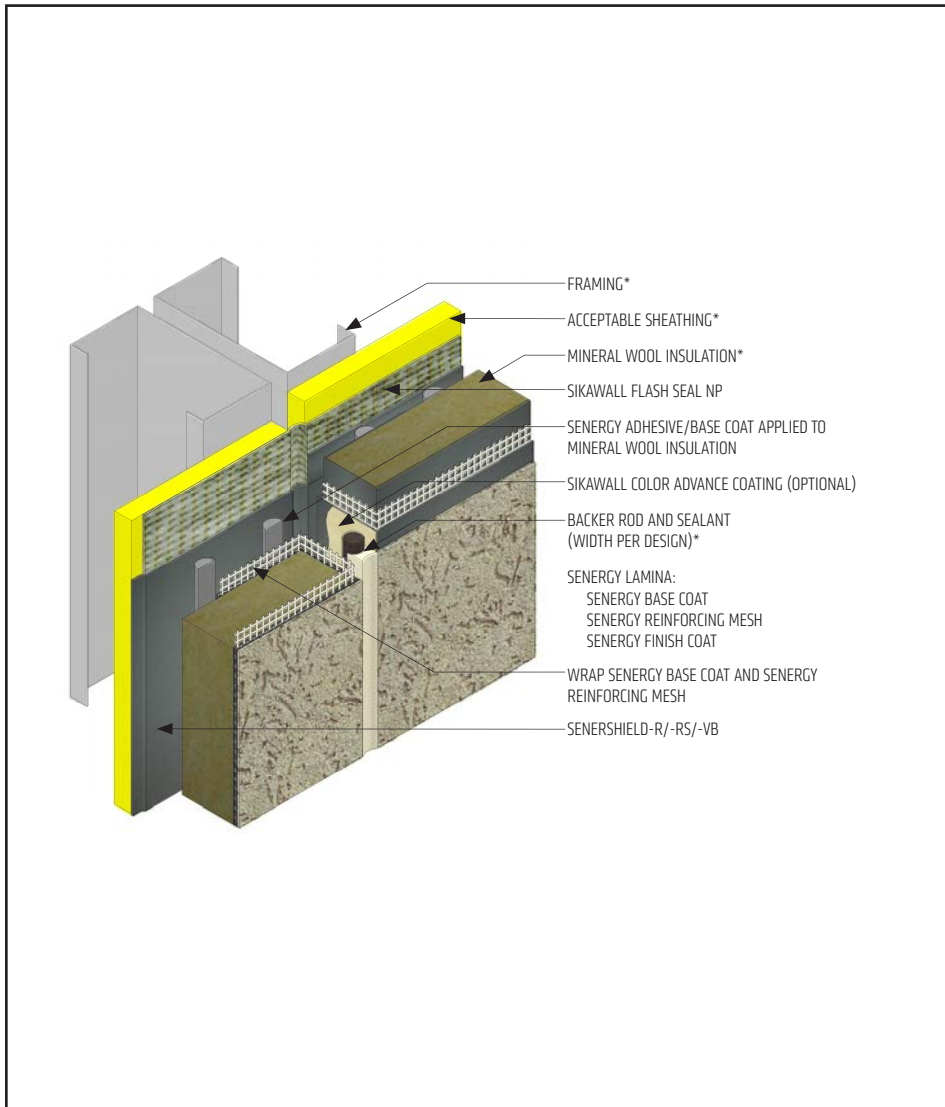

- All terminations must be fully encapsulated with mesh reinforced base coat. Extend reinforcing mesh a minimum of 2 1/2" onto back of insulation board.
- Ensure drainage plane is continuous and unobstructed at expansion joint.
- Do not apply finish to areas that will receive sealant.
- Typical locations for system expansion joints are at building expansion joints, at prefabricated panel joints, floor lines of wood frame construction or where slip tracks are used in steel frame construction, where substrates change and where structural movement is anticipated. It is the sole responsibility of the project design team, including the architect, engineer, etc., to ultimately determine specific expansion joint placement, width and design. Detail specific locations in construction drawings.
- Provide sufficient slack in SikaWall Flash Seal NP at expansion joint to allow for movement.
- Reference *Acceptable Sealants for use with Senergy Wall Systems* Technical Bulletin for a list of sealants.

VNC-07 2401

(*NOTE: BY OTHERS)

The details within are the latest recommendations and are represented in good faith by Sika Corporation US (hereinafter Sika). The details are subject to change without notice. Sika accepts no liability for the end use of the details. For conditions not shown, consult Sika for review of specific details.

- Install Sika materials in accordance with current installation instructions.
- Unsatisfactory conditions shall be reported to the General Contractor and corrected before the application of Sika products.

Senerflex Vulcan NC System

TYPICAL EXPANSION JOINT AT CHANGE IN SUBSTRATE

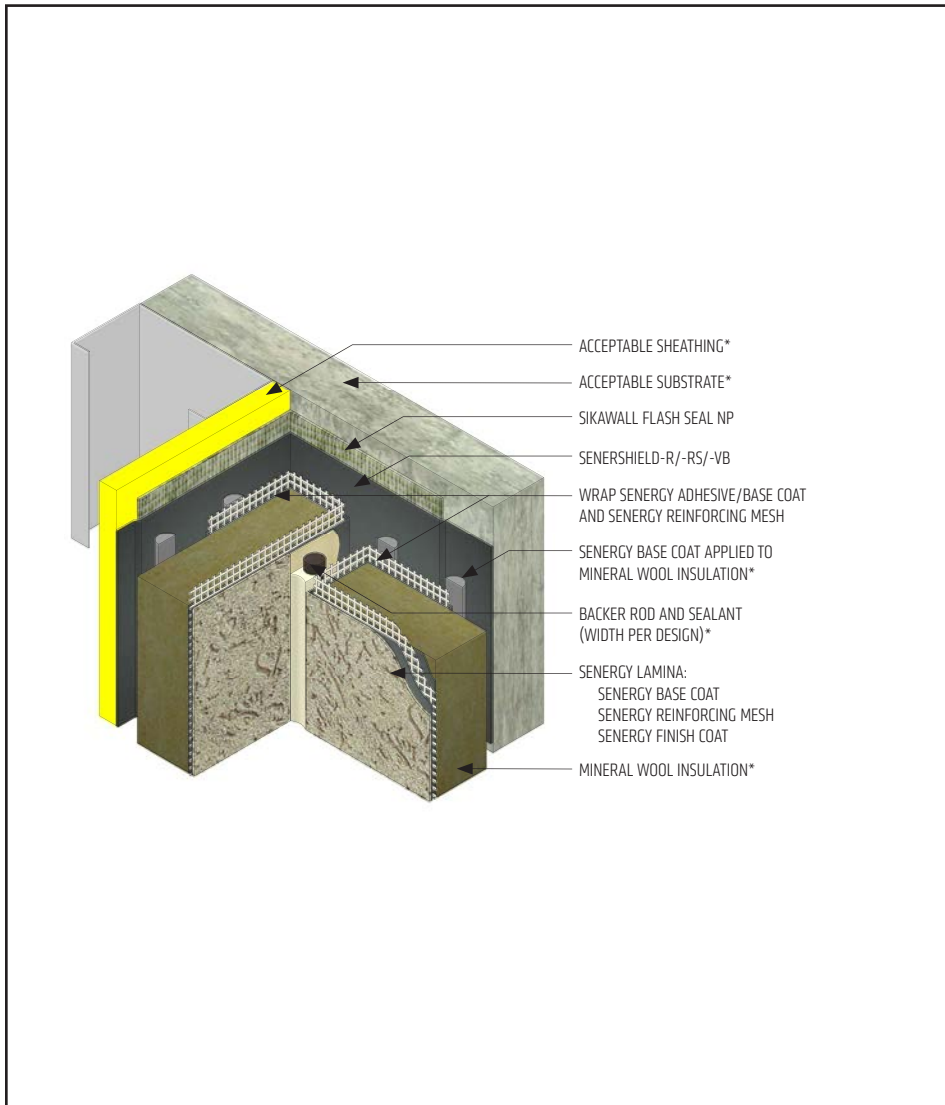

- All terminations must be fully encapsulated with mesh reinforced base coat.
- Ensure drainage plane is continuous and unobstructed at expansion joint.
- Do not apply finish to areas that will receive sealant.
- Typical locations for system expansion joints are at building expansion joints, at prefabricated panel joints, floor lines of wood frame construction or where slip tracks are used in steel frame construction, where substrates change and where structural movement is anticipated. It is the sole responsibility of the project design team, including the architect, engineer, etc., to ultimately determine specific expansion joint placement, width and design. Detail specific locations in construction drawings.
- Provide sufficient slack in SikaWall Flash Seal NP at expansion joint to allow for movement.
- Reference *Acceptable Sealants for use with Senergy Wall Systems* Technical Bulletin for a list of sealants.

VNC-08 2401

(*NOTE: BY OTHERS)

The details within are the latest recommendations and are represented in good faith by Sika Corporation US (hereinafter Sika). The details are subject to change without notice. Sika accepts no liability for the end use of the details. For conditions not shown, consult Sika for review of specific details.

- Install Sika materials in accordance with current installation instructions.
- Unsatisfactory conditions shall be reported to the General Contractor and corrected before the application of Sika products.

Senerflex Vulcan NC System

TYPICAL EXPANSION JOINT AT FLOORLINE

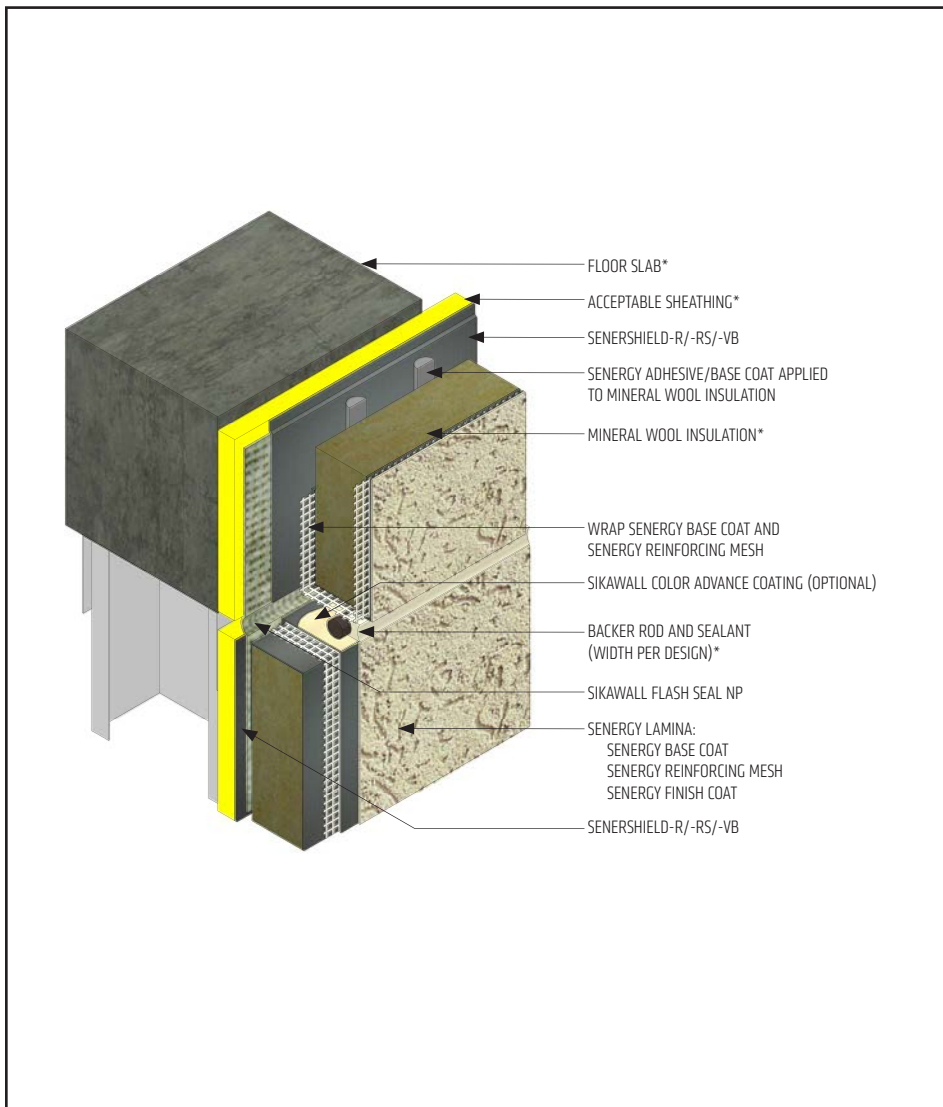

VNC-09 2401

(*NOTE: BY OTHERS)

- All terminations must be fully encapsulated with mesh reinforced base coat.
- Ensure drainage plane is continuous and unobstructed at expansion joint.
- Do not apply finish to areas that will receive sealant.
- Typical locations for system expansion joints are at building expansion joints, at prefabricated panel joints, floor lines of wood frame construction or where slip tracks are used in steel frame construction, where substrates change and where structural movement is anticipated. It is the sole responsibility of the project design team, including the architect, engineer, etc., to ultimately determine specific expansion joint placement, width and design. Detail specific locations in construction drawings.
- It is recommended that a means for drainage is provided at every third floor (See Detail VNC-10).
- Pre-backwrapping is recommended at drainage terminations. Extend reinforcing mesh a minimum of 2 1/2" onto back of insulation board.
- Provide sufficient slack in SikaWall Flash Seal NP at expansion joint to allow for movement.
- Reference *Acceptable Sealants for use with Senergy Wall Systems* Technical Bulletin for a list of sealants.

The details within are the latest recommendations and are represented in good faith by Sika Corporation US (hereinafter Sika). The details are subject to change without notice. Sika accepts no liability for the end use of the details. For conditions not shown, consult Sika for review of specific details.

- Install Sika materials in accordance with current installation instructions.
- Unsatisfactory conditions shall be reported to the General Contractor and corrected before the application of Sika products.

Senerflex Vulcan NC System

TYPICAL DRAINAGE AT FLOORLINE

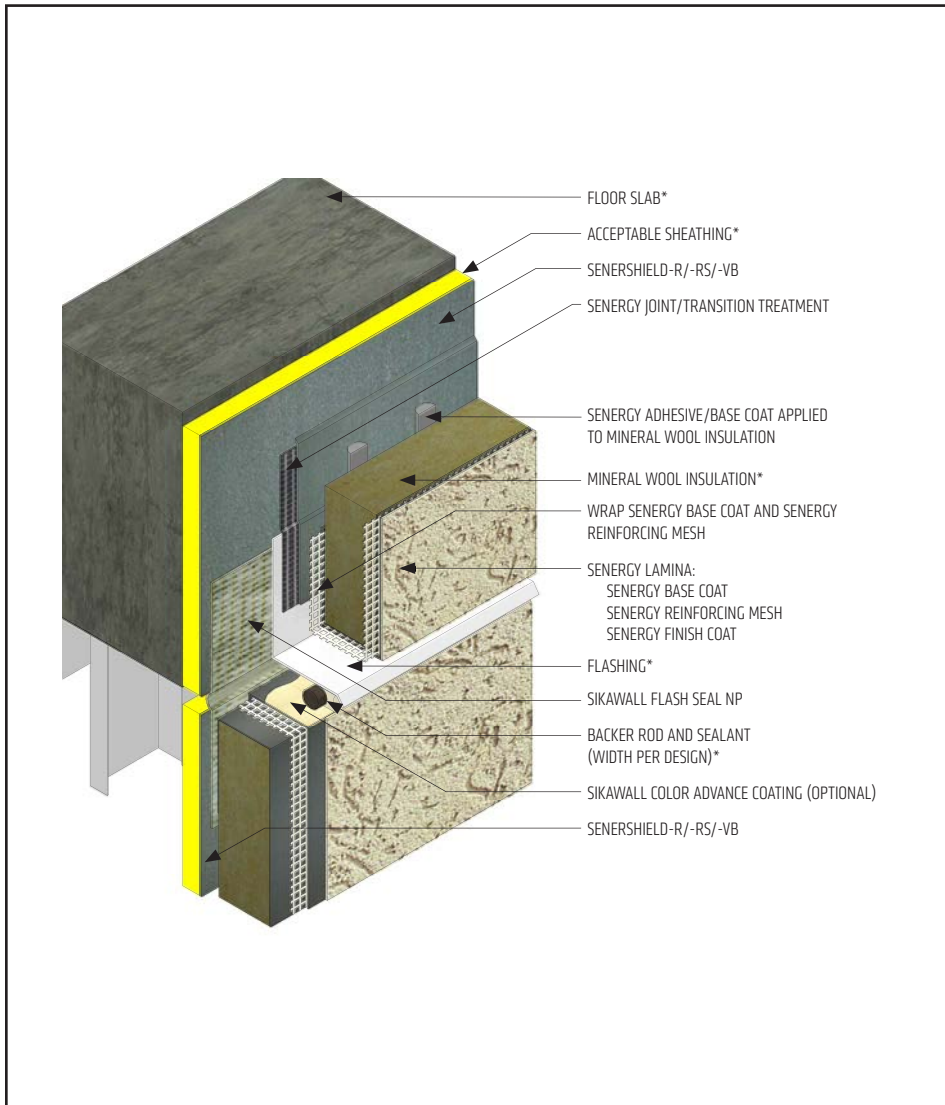

VNC-10 2401

(*NOTE: BY OTHERS)

- All terminations must be fully encapsulated with mesh reinforced base coat. Pre-backwrapping is recommended at drainage terminations. Extend reinforcing mesh a minimum of 2 1/2" onto back of insulation board.
- Ensure drainage plane is continuous and unobstructed at expansion joint.
- Do not apply finish to areas that will receive sealant.
- Typical locations for system expansion joints are at building expansion joints, at prefabricated panel joints, floor lines of wood frame construction or where slip tracks are used in steel frame construction, where substrates change and where structural movement is anticipated. It is the sole responsibility of the project design team, including the architect, engineer, etc., to ultimately determine specific expansion joint placement, width and design. Detail specific locations in construction drawings.
- Senergy Joint/Transition Treatment Options: SikaWall MaxFlash, SikaWall Sheathing Fabric embedded in Senershield-R/-RS/-VB or SikaWall Flash Seal NP.
- Provide sufficient slack in SikaWall Flash Seal NP at expansion joint to allow for movement.

The details within are the latest recommendations and are represented in good faith by Sika Corporation US (hereinafter Sika). The details are subject to change without notice. Sika accepts no liability for the end use of the details. For conditions not shown, consult Sika for review of specific details.

- Install Sika materials in accordance with current installation instructions.
- Unsatisfactory conditions shall be reported to the General Contractor and corrected before the application of Sika products.

Senerflex Vulcan NC System

TYPICAL EIFS ABUTMENT TO BRICK WITH DRAINAGE AT FLOORLINE

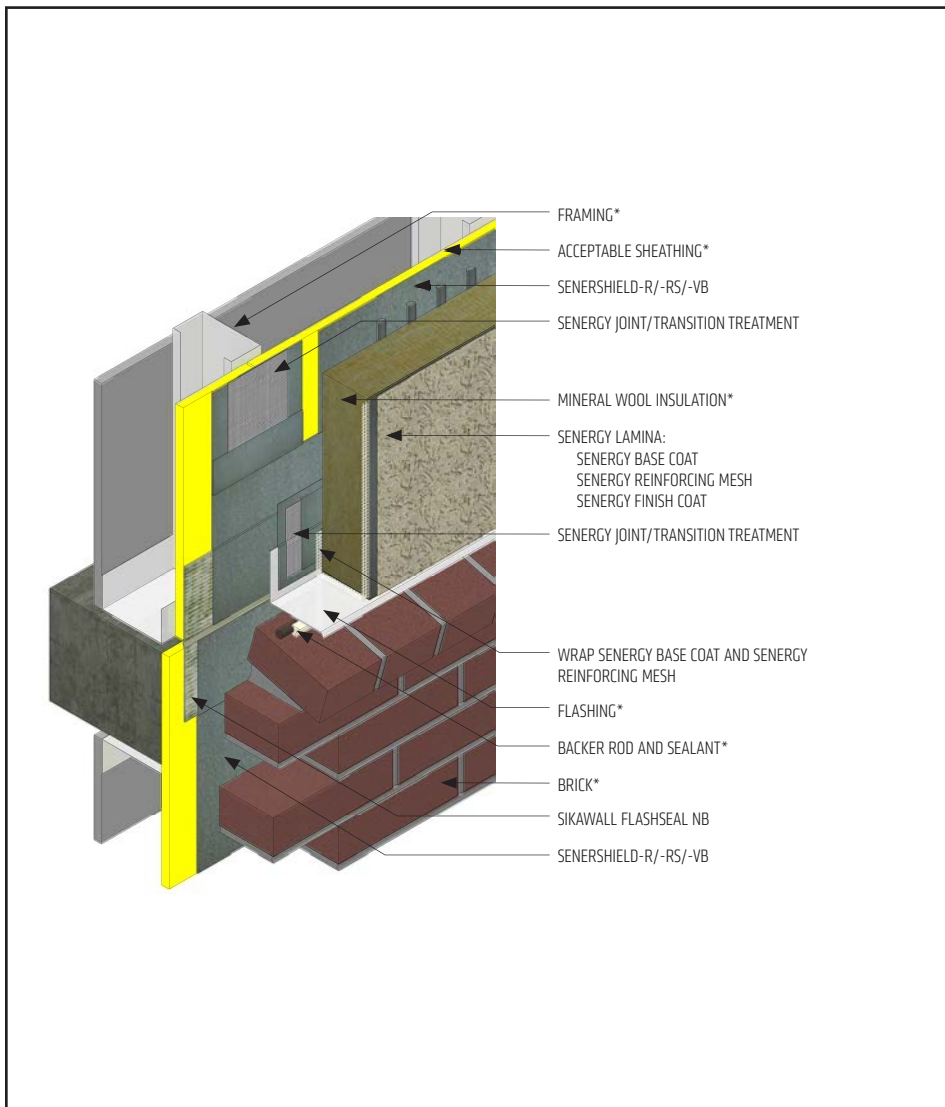

VNC-11 2401

(*NOTE: BY OTHERS)

The details within are the latest recommendations and are represented in good faith by Sika Corporation US (hereinafter Sika). The details are subject to change without notice. Sika accepts no liability for the end use of the details. For conditions not shown, consult Sika for review of specific details.

- Install Sika materials in accordance with current installation instructions.
- Unsatisfactory conditions shall be reported to the General Contractor and corrected before the application of Sika products.

- All terminations must be fully encapsulated with mesh reinforced base coat. Pre-backwrapping is recommended at drainage terminations. Extend reinforcing mesh a minimum of 2 1/2" onto back of insulation board.
- Brick must be installed per local code requirements.
- Senergy Joint/Transition Treatment Options: SikaWall MaxFlash, SikaWall Sheathing Fabric embedded in Senershield-R/-RS/-VB or SikaWall Flash Seal NP.
- Provide sufficient slack in SikaWall Flash Seal NP at expansion joint to allow for movement.
- Ensure a means for drainage is provided at system termination at brick.

Senerflex Vulcan NC System

TYPICAL EIFS ABUTMENT TO BRICK WITH CONTINUOUS DRAINAGE

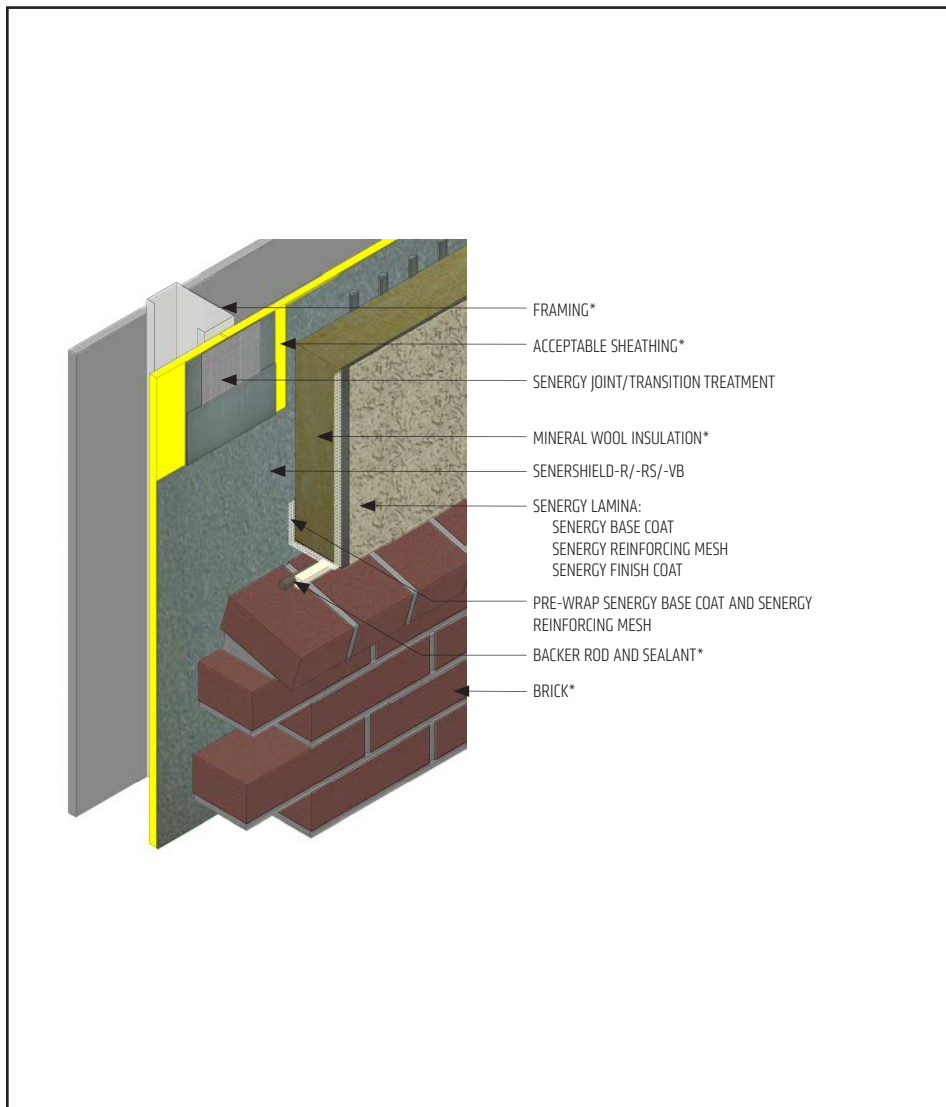

- All terminations must be fully encapsulated with mesh reinforced base coat. Pre-backwrapping is recommended at drainage terminations. Extend reinforcing mesh a minimum of 2 1/2" onto back of insulation board.
- Ensure a continuous drainage plane is maintained at system abutment to brick.
- Brick must be installed per local code requirements.
- Senergy Joint/Transition Treatment Options: SikaWall MaxFlash, SikaWall Sheathing Fabric embedded in Senershield-R/-RS/-VB or SikaWall Flash Seal NP.
- Reference *Acceptable Sealants for use with Senergy Wall Systems* Technical Bulletin for a list of sealants.

VNC-12 2401

(*NOTE: BY OTHERS)

The details within are the latest recommendations and are represented in good faith by Sika Corporation US (hereinafter Sika). The details are subject to change without notice. Sika accepts no liability for the end use of the details. For conditions not shown, consult Sika for review of specific details.

- Install Sika materials in accordance with current installation instructions.
- Unsatisfactory conditions shall be reported to the General Contractor and corrected before the application of Sika products.

Senerflex Vulcan NC System

TYPICAL TERMINATION AT FOUNDATION

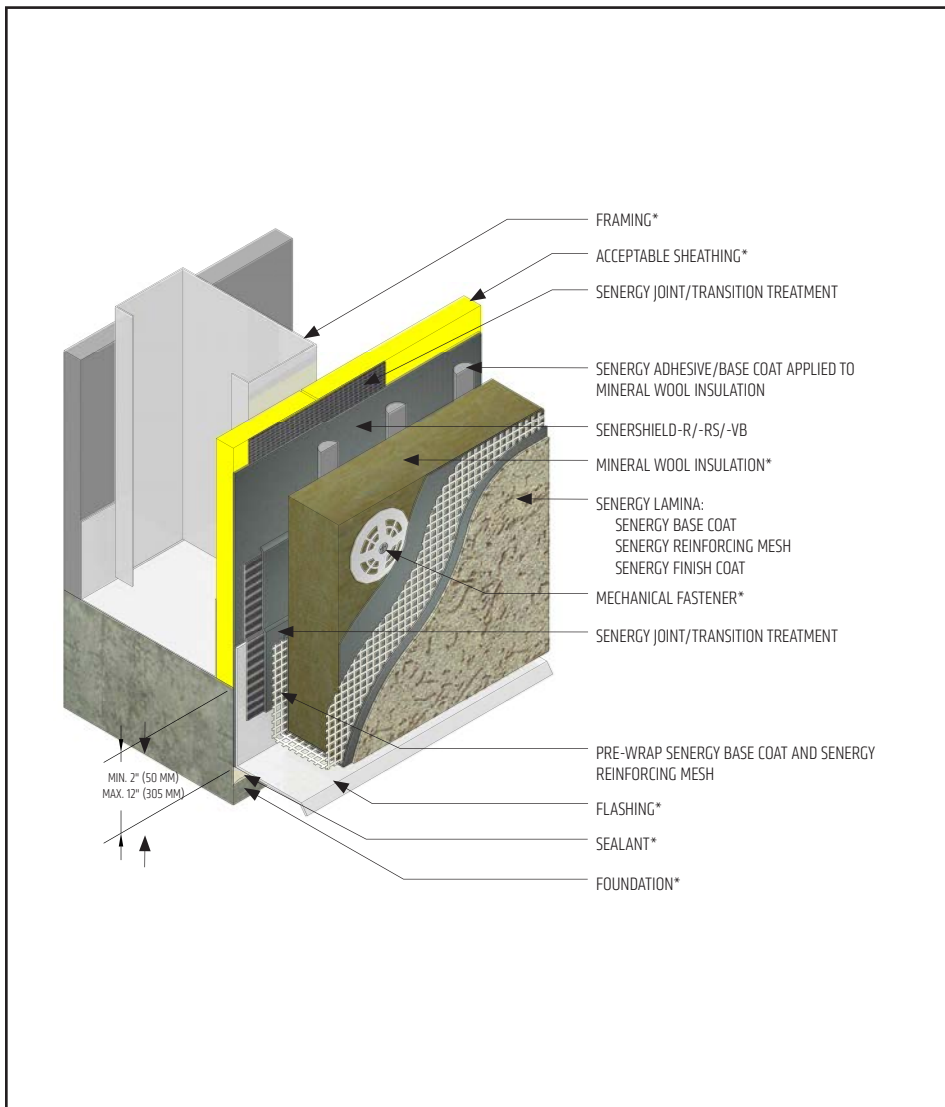

- All terminations must be fully encapsulated with mesh reinforced base coat. Pre-backwrapping is recommended at drainage terminations. Extend reinforcing mesh a minimum of 2 1/2" onto back of insulation board.
- Ensure a means for drainage is provided at system termination at foundation.
- Terminate system a minimum of 6" (152 mm) above grade.
- Extend system a minimum of 2" (50 mm) and a maximum of 12" (305 mm) at the sole plate foundation transition.
- Provide SikaWall MaxFlash, SikaWall Sheathing Fabric embedded in Senershield-R/-RS/-VB or SikaWall Flash Seal NP at transition from sheathing to concrete (behind flashing).
- Senergy Joint/Transition Treatment Options: SikaWall MaxFlash, SikaWall Sheathing Fabric embedded in Senershield-R/-RS/-VB or SikaWall Flash Seal NP.

VNC-13 2401

(*NOTE: BY OTHERS)

The details within are the latest recommendations and are represented in good faith by Sika Corporation US (hereinafter Sika). The details are subject to change without notice. Sika accepts no liability for the end use of the details. For conditions not shown, consult Sika for review of specific details.

- Install Sika materials in accordance with current installation instructions.
- Unsatisfactory conditions shall be reported to the General Contractor and corrected before the application of Sika products.

Senerflex Vulcan NC System

TYPICAL TERMINATION AT FOUNDATION (FLUSH)

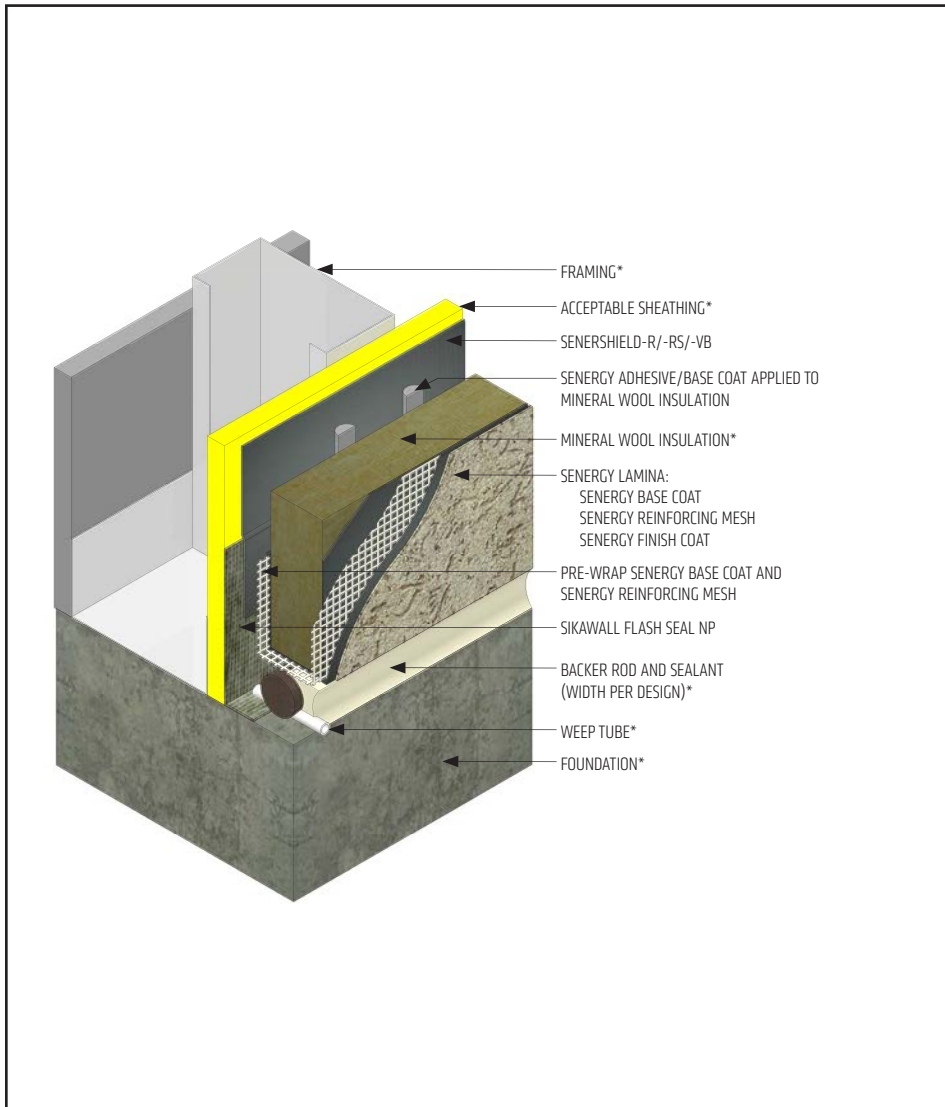

- All terminations must be fully encapsulated with mesh reinforced base coat. Pre-backwrapping is recommended at drainage terminations. Extend reinforcing mesh a minimum of 2 1/2" onto back of insulation board.
- Ensure a means for drainage is provided at system termination at foundation.
- Place weep tubes a maximum of 24" (610 mm) on center.
- Do not apply finish to areas that will receive sealant.
- Reference *Acceptable Sealants for use with Senergy Wall System* Technical Bulletin for a list of sealants.

VNC-14 2401

(*NOTE: BY OTHERS)

The details within are the latest recommendations and are represented in good faith by Sika Corporation US (hereinafter Sika). The details are subject to change without notice. Sika accepts no liability for the end use of the details. For conditions not shown, consult Sika for review of specific details.

- Install Sika materials in accordance with current installation instructions.
- Unsatisfactory conditions shall be reported to the General Contractor and corrected before the application of Sika products.

Senerflex Vulcan NC System

TYPICAL WINDOW HEAD (FLUSH)

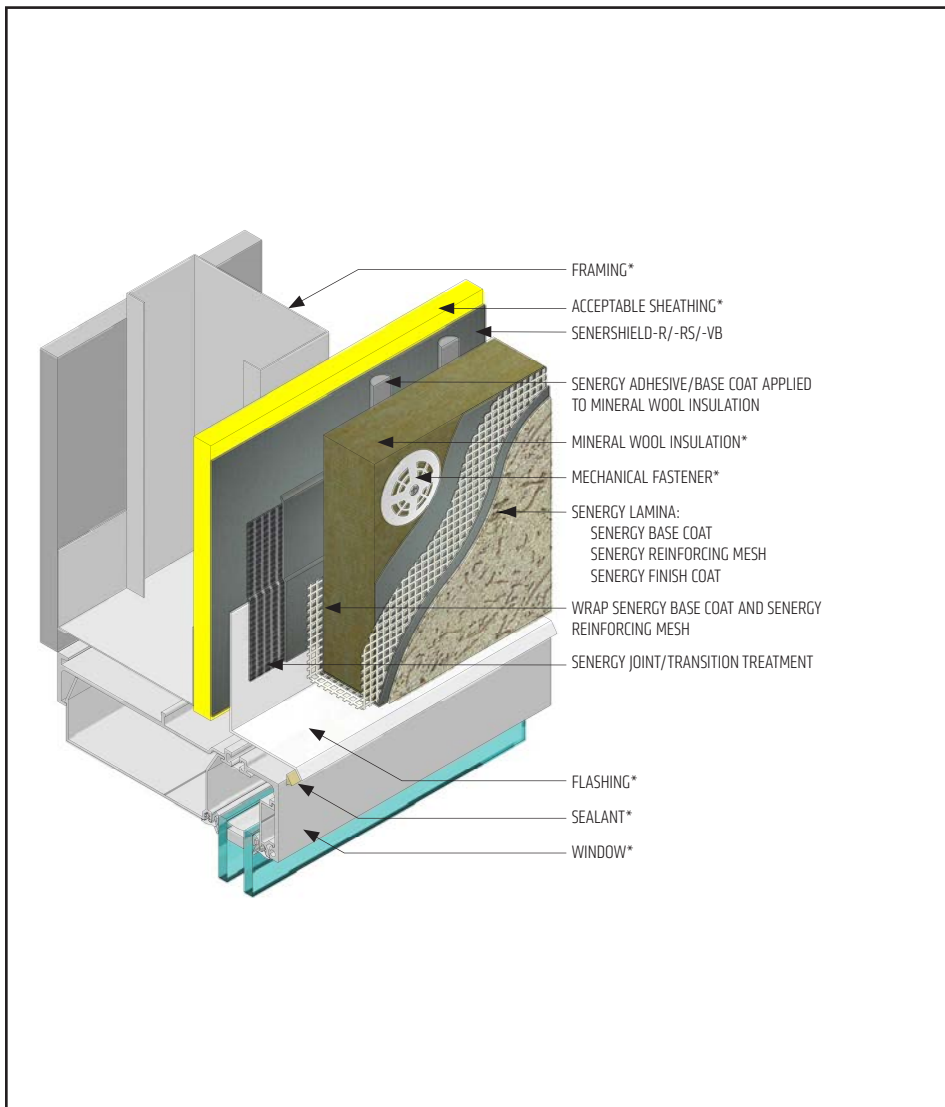

VNC-15 2401

(*NOTE: BY OTHERS)

- All terminations must be fully encapsulated with mesh reinforced base coat. Pre-backwrapping is recommended at drainage terminations. Extend reinforcing mesh a minimum of 2 1/2" onto back of insulation board.
- Ensure a means for drainage is provided at system termination at window head.
- Provide end-dams at flashing terminations.
- Consult window and sealant manufacturers to verify window installation, detailing and to ensure no water leakage into the wall assembly.
- Prior to window and mineral wool installation, ensure the water-resistive barrier is properly applied into the rough openings in accordance with Senergy application guidelines and code requirements. Reference Senergy Senershield published typical details.
- Senergy Joint/Transition Treatment Options: SikaWall MaxFlash, SikaWall Sheathing Fabric embedded in Senershield-R/-RS/-VB or SikaWall Flash Seal NP.

The details within are the latest recommendations and are represented in good faith by Sika Corporation US (hereinafter Sika). The details are subject to change without notice. Sika accepts no liability for the end use of the details. For conditions not shown, consult Sika for review of specific details.

- Install Sika materials in accordance with current installation instructions.
- Unsatisfactory conditions shall be reported to the General Contractor and corrected before the application of Sika products.

Senerflex Vulcan NC System

TYPICAL WINDOW HEAD (FLUSH) WITH WEEP TUBES

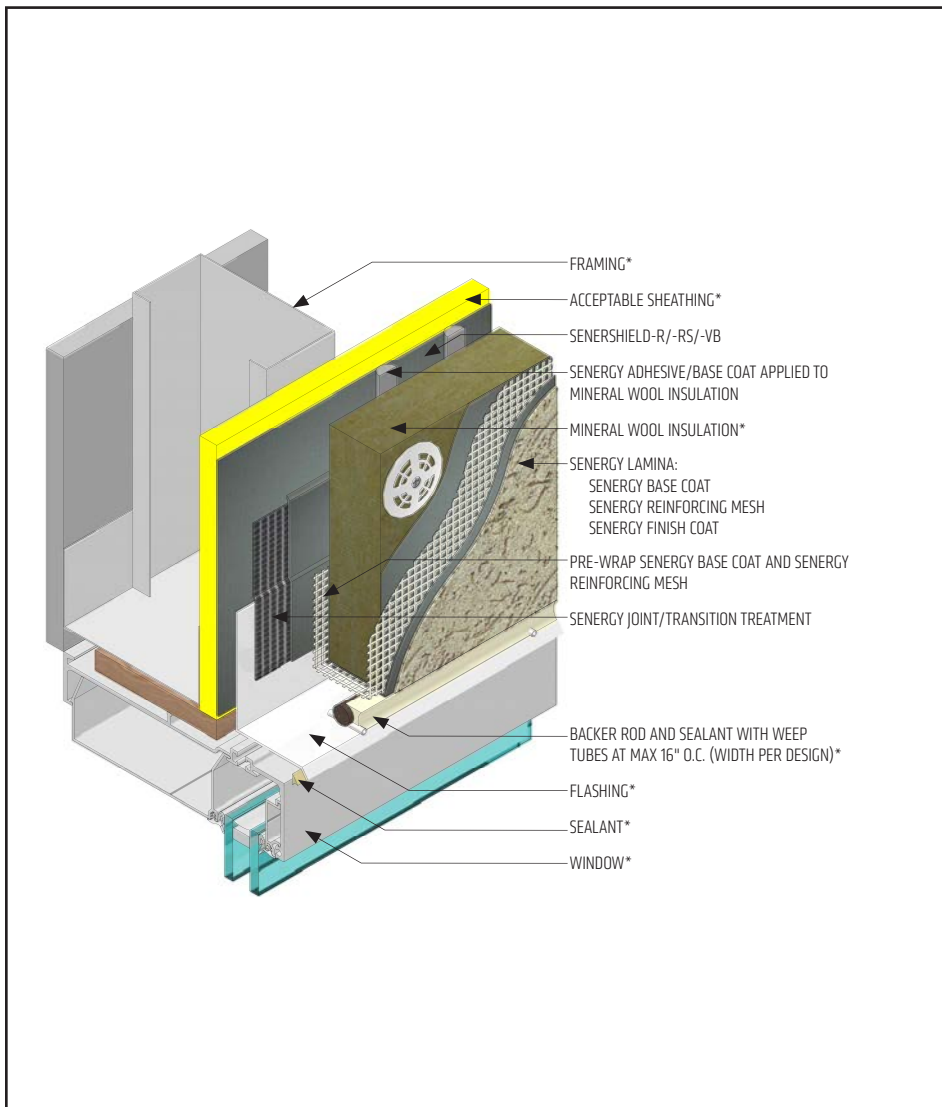

VNC-16 2401

(*NOTE: BY OTHERS)

- All terminations must be fully encapsulated with mesh reinforced base coat. Pre-backwrapping is recommended at drainage terminations. Extend reinforcing mesh a minimum of 2 1/2" onto back of insulation board.
- Ensure a means for drainage is provided at system termination at window head.
- Provide end-dams at flashing terminations.
- Consult window and sealant manufacturers to verify window installation, detailing and to ensure no water leakage into the wall assembly.
- Prior to window and mineral wool installation, ensure the water-resistive barrier is properly applied into the rough openings in accordance with Senergy application guidelines and code requirements. Reference Senergy Senershield published typical details.
- Place weep tubes a maximum of 16" (406 mm) on center.
- Senergy Joint/Transition Treatment Options: SikaWall MaxFlash, SikaWall Sheathing Fabric embedded in Senershield-R/-RS/-VB or SikaWall Flash Seal NP.

The details within are the latest recommendations and are represented in good faith by Sika Corporation US (hereinafter Sika). The details are subject to change without notice. Sika accepts no liability for the end use of the details. For conditions not shown, consult Sika for review of specific details.

- Install Sika materials in accordance with current installation instructions.
- Unsatisfactory conditions shall be reported to the General Contractor and corrected before the application of Sika products.

Senerflex Vulcan NC System

TYPICAL WINDOW HEAD (RECESSED)

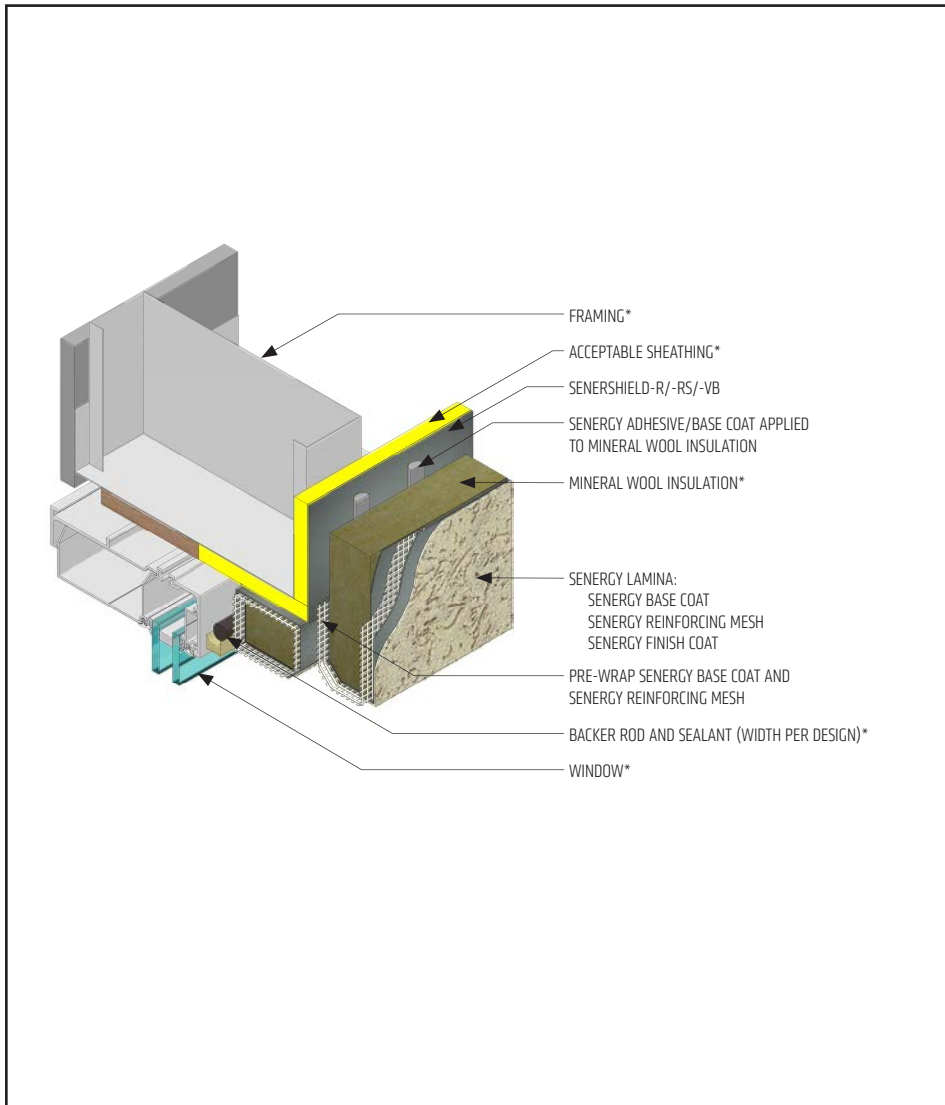

- All terminations must be fully encapsulated with mesh reinforced base coat. Pre-backwrapping is recommended at drainage terminations. Extend reinforcing mesh a minimum of 2 1/2" onto back of insulation board.
- Ensure a means for drainage is provided at system termination at window head.
- Consult window and sealant manufacturers to verify window installation, detailing and to ensure no water leakage into the wall assembly.
- Prior to window and mineral wool installation, ensure the water-resistive barrier is properly applied into the rough openings in accordance with Senergy application guidelines and code requirements. Reference Senergy Senershield published typical details.
- Do not apply finish in areas that will receive sealant.
- Reference *Acceptable Sealants for Use with Senergy Wall Systems* Technical Bulletin for a list of sealants.

VNC-17 2401

(*NOTE: BY OTHERS)

The details within are the latest recommendations and are represented in good faith by Sika Corporation US (hereinafter Sika). The details are subject to change without notice. Sika accepts no liability for the end use of the details. For conditions not shown, consult Sika for review of specific details.

- Install Sika materials in accordance with current installation instructions.
- Unsatisfactory conditions shall be reported to the General Contractor and corrected before the application of Sika products.

Senerflex Vulcan NC System

TYPICAL WINDOW JAMB (FLUSH)

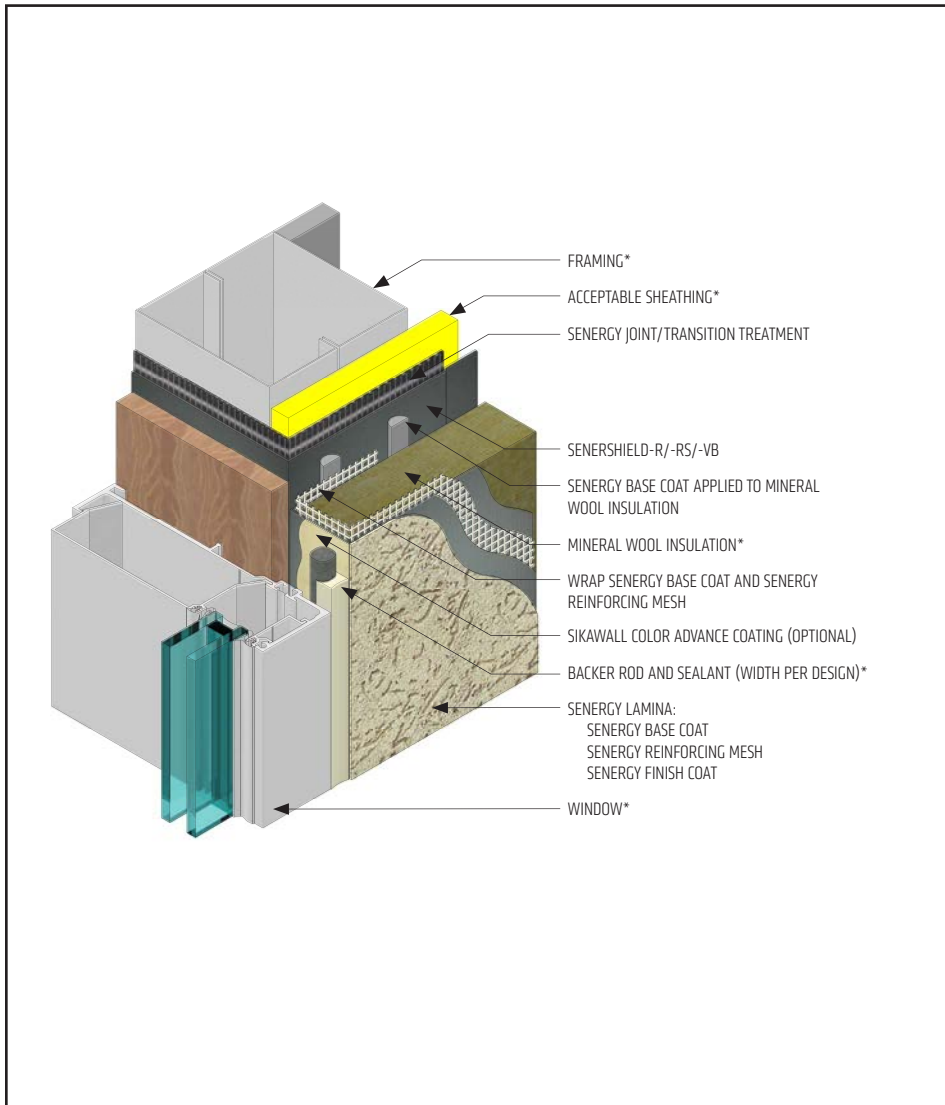

- All terminations must be fully encapsulated with mesh reinforced base coat.
- Consult window and sealant manufacturers to verify window installation, detailing and to ensure no water leakage into the wall assembly.
- Prior to window and mineral wool installation, ensure the water-resistive barrier is properly applied into the rough openings in accordance with Senergy application guidelines and code requirements. Reference Senergy Senershield published typical details.
- Do not apply finish in areas that will receive sealant.
- Provide a back wrapped type joint with backer rod and sealant at system terminations to dissimilar materials, ensuring that a water tight seal is achieved (width per design).
- Senergy Joint/Transition Treatment Options: SikaWall MaxFlash, SikaWall Sheathing Fabric embedded in Senershield-R/-RS/-VB or SikaWall Flash Seal NP.

VNC-18 2401

(*NOTE: BY OTHERS)

The details within are the latest recommendations and are represented in good faith by Sika Corporation US (hereinafter Sika). The details are subject to change without notice. Sika accepts no liability for the end use of the details. For conditions not shown, consult Sika for review of specific details.

- Install Sika materials in accordance with current installation instructions.
- Unsatisfactory conditions shall be reported to the General Contractor and corrected before the application of Sika products.

Senerflex Vulcan NC System

TYPICAL WINDOW SILL (FLUSH)

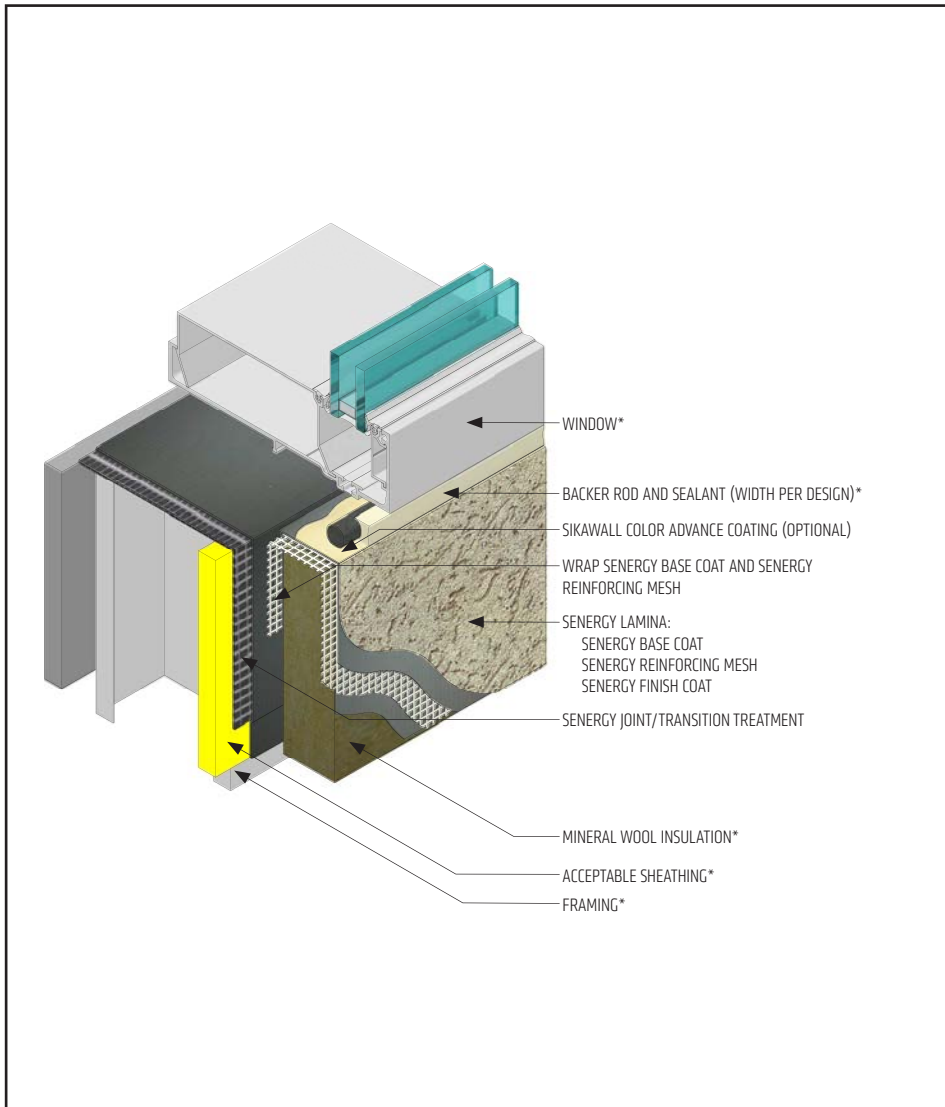

VNC-19 2401

(*NOTE: BY OTHERS)

- All terminations must be fully encapsulated with mesh reinforced base coat.
- Consult window and sealant manufacturers to verify window installation, detailing and to ensure no water leakage into the wall assembly.
- Prior to window and mineral wool installation, ensure the water-resistive barrier is properly applied into the rough openings in accordance with Senergy application guidelines and code requirements. Reference Senergy Senershield published typical details.
- Do not apply finish in areas that will receive sealant.
- Provide a back wrapped type joint with backer rod and sealant at system terminations to dissimilar materials, ensuring that a water tight seal is achieved (width per design).
- Senergy Joint/Transition Treatment Options: SikaWall MaxFlash, SikaWall Sheathing Fabric embedded in Senershield-R/-RS/-VB or SikaWall Flash Seal NP.

The details within are the latest recommendations and are represented in good faith by Sika Corporation US (hereinafter Sika). The details are subject to change without notice. Sika accepts no liability for the end use of the details. For conditions not shown, consult Sika for review of specific details.

- Install Sika materials in accordance with current installation instructions.
- Unsatisfactory conditions shall be reported to the General Contractor and corrected before the application of Sika products.

Senerflex Vulcan NC System

TYPICAL WINDOW JAMB (RECESSED)

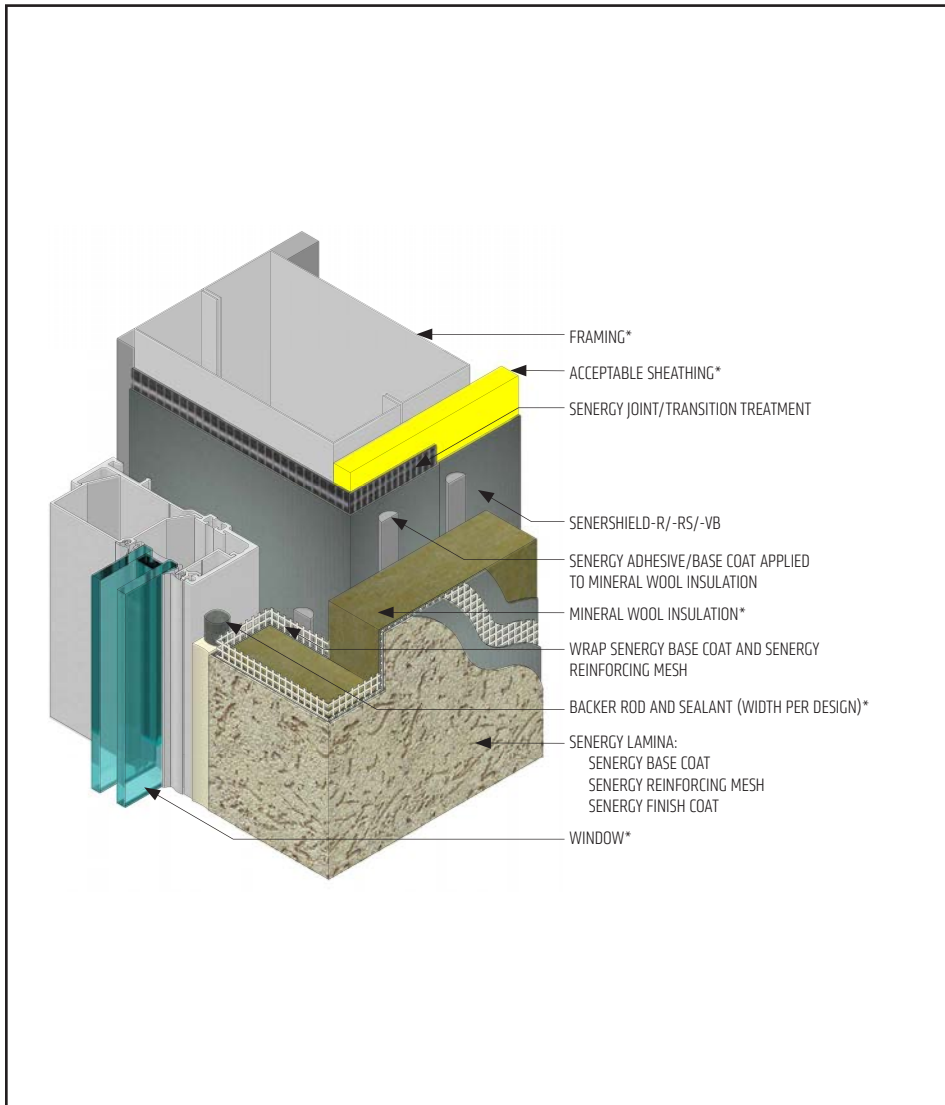

VNC-20 2401

(*NOTE: BY OTHERS)

- All terminations must be fully encapsulated with mesh reinforced base coat.
- Consult window and sealant manufacturers to verify window installation, detailing and to ensure no water leakage into the wall assembly.
- Prior to window and mineral wool installation, ensure the water-resistive barrier is properly applied into the rough openings in accordance with Senergy application guidelines and code requirements. Reference Senergy Senershield published typical details.
- Do not apply finish in areas that will receive sealant.
- Provide a back wrapped type joint with backer rod and sealant at system terminations to dissimilar materials, ensuring that a water tight seal is achieved (width per design).
- Senergy Joint/Transition Treatment Options: SikaWall MaxFlash, SikaWall Sheathing Fabric embedded in Senershield-R/-RS/-VB or SikaWall Flash Seal NP.

The details within are the latest recommendations and are represented in good faith by Sika Corporation US (hereinafter Sika). The details are subject to change without notice. Sika accepts no liability for the end use of the details. For conditions not shown, consult Sika for review of specific details.

- Install Sika materials in accordance with current installation instructions.
- Unsatisfactory conditions shall be reported to the General Contractor and corrected before the application of Sika products.

Senerflex Vulcan NC System

TYPICAL WINDOW SILL (RECESSED)

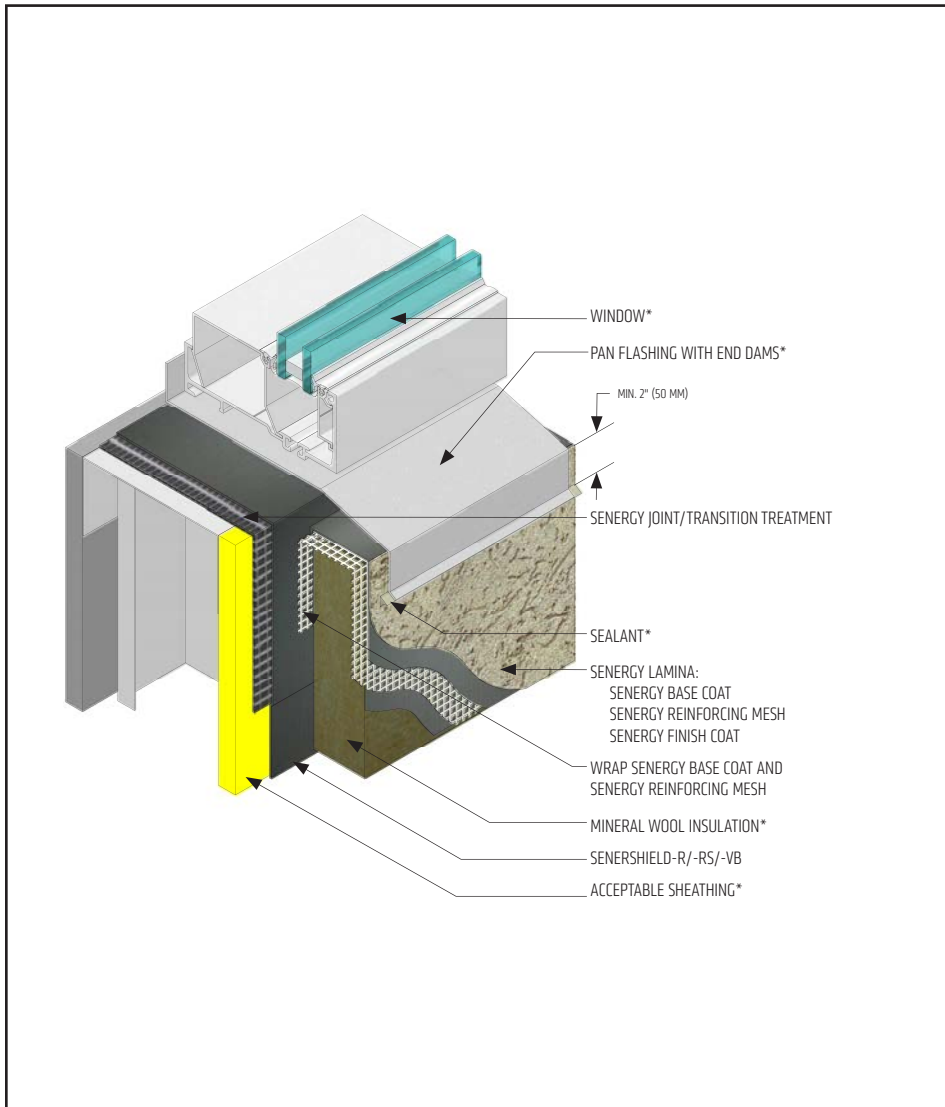

- All terminations must be fully encapsulated with mesh reinforced base coat.
- Consult window and sealant manufacturers to verify window installation, detailing and to ensure no water leakage into the wall assembly.
- Prior to window and mineral wool installation, ensure the water-resistive barrier is properly applied into the rough openings in accordance with Senergy application guidelines and code requirements. Reference Senergy Senershield published typical details.
- Ensure that pan flashing extends onto the system a minimum of 2" (50 mm) down the face and that end dams are provided. Transition on to end-dams with transition treatment.
- Senergy Joint/Transition Treatment Options: SikaWall MaxFlash, SikaWall Sheathing Fabric embedded in Senershield-R/-RS/-VB or SikaWall Flash Seal NP.

VNC-21 2401

(*NOTE: BY OTHERS)

The details within are the latest recommendations and are represented in good faith by Sika Corporation US (hereinafter Sika). The details are subject to change without notice. Sika accepts no liability for the end use of the details. For conditions not shown, consult Sika for review of specific details.

- Install Sika materials in accordance with current installation instructions.
- Unsatisfactory conditions shall be reported to the General Contractor and corrected before the application of Sika products.

Senerflex Vulcan NC System

TYPICAL PARAPET CAP FLASHING

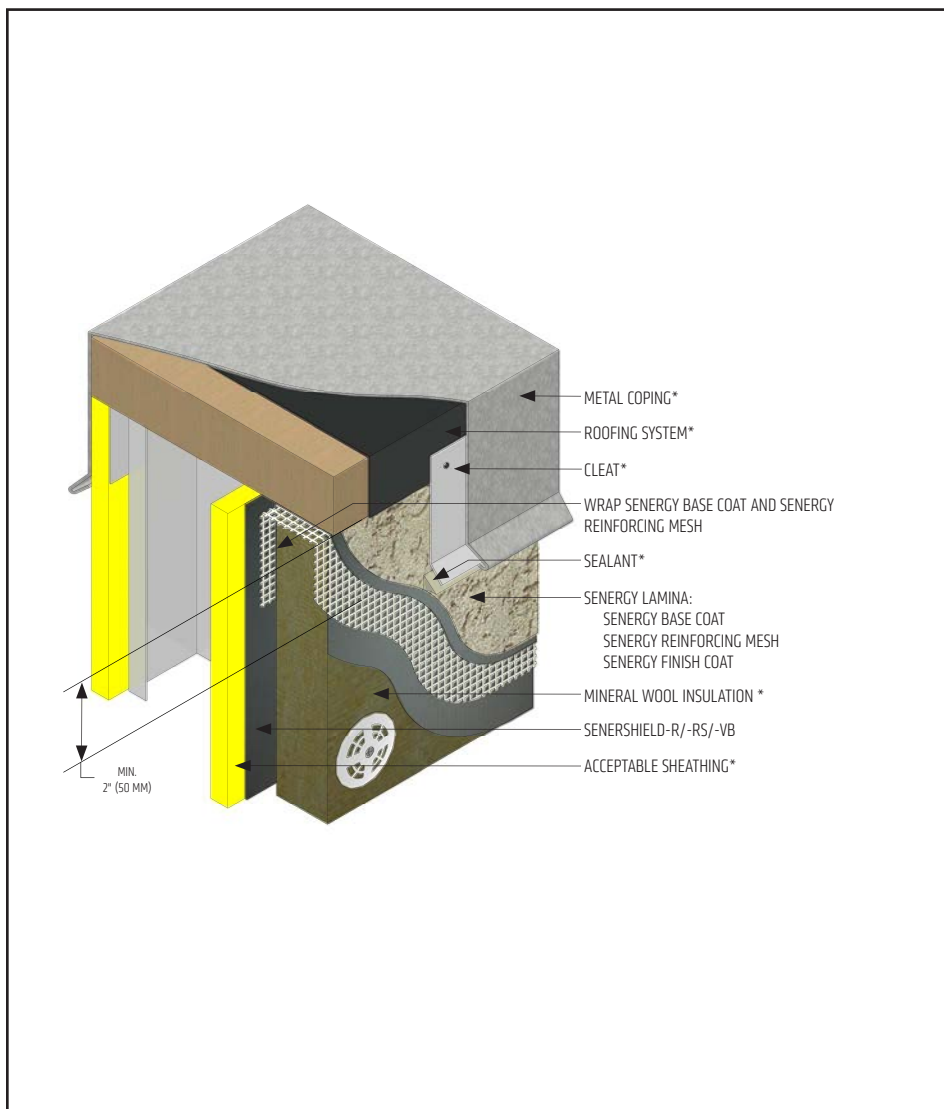

- All terminations must be fully encapsulated with mesh reinforced base coat.
- Ensure that metal coping/flashing extends onto the system a minimum of 2" (50 mm) down the face.
- Extend Senershield-R/-RS/-VB or SikaWall MaxFlash onto bottom of blocking or provide alternate air seal at sheathing termination to blocking.
- Reference *Acceptable Sealants for use with Senergy Wall Systems* Technical Bulletin for a list of sealants.

VNC-22 2401

(*NOTE: BY OTHERS)

The details within are the latest recommendations and are represented in good faith by Sika Corporation US (hereinafter Sika). The details are subject to change without notice. Sika accepts no liability for the end use of the details. For conditions not shown, consult Sika for review of specific details.

- Install Sika materials in accordance with current installation instructions.
- Unsatisfactory conditions shall be reported to the General Contractor and corrected before the application of Sika products.

Senerflex Vulcan NC System

TYPICAL KICK-OUT FLASHING



- All terminations must be fully encapsulated with mesh reinforced base coat. Pre-backwrapping is recommended at drainage terminations. Extend reinforcing mesh a minimum of 2 1/2" onto back of insulation board.
- Ensure a means for drainage is provided at system termination at roof.
- Terminate system a minimum of 2" (50 mm) above sloped roof.
- Ensure step flashing is a minimum of 2" (50 mm) behind system.
- Kick-out flashing shall be a minimum of 4" (102 mm) in height.
- Do not apply finish to areas that will receive sealant.
- Senergy Joint/Transition Treatment Options: SikaWall MaxFlash, SikaWall Sheathing Fabric embedded in Senershield-R/-RS/-VB or SikaWall Flash Seal NP.

VNC-23 2401

(*NOTE: BY OTHERS)

The details within are the latest recommendations and are represented in good faith by Sika Corporation US (hereinafter Sika). The details are subject to change without notice. Sika accepts no liability for the end use of the details. For conditions not shown, consult Sika for review of specific details.

- Install Sika materials in accordance with current installation instructions.
- Unsatisfactory conditions shall be reported to the General Contractor and corrected before the application of Sika products.

Senerflex Vulcan NC System

ROOF EDGE FLASHING

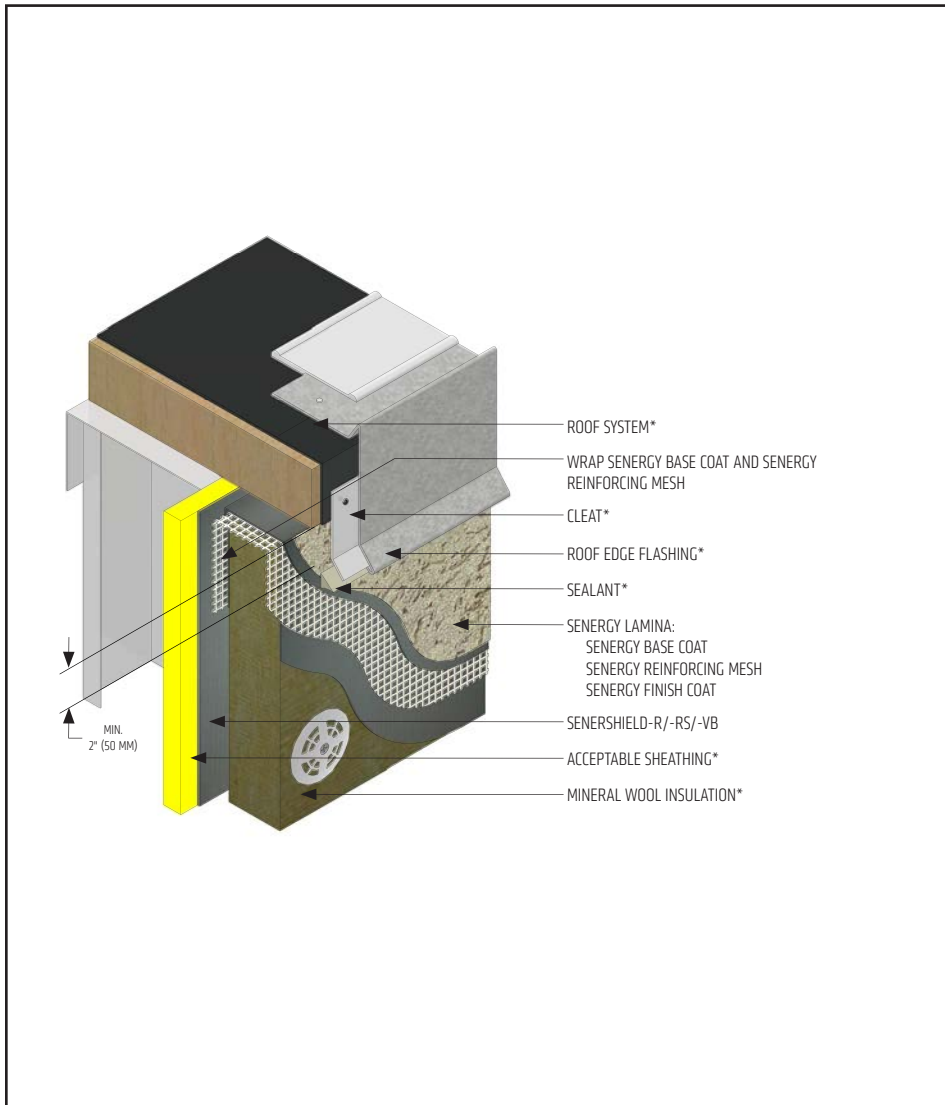

- All terminations must be fully encapsulated with mesh reinforced base coat. Extend reinforcing mesh a minimum of 2 1/2" onto back of insulation board.
- Ensure that metal coping/flashing extends onto the system a minimum of 2" (50 mm) down the face.
- Extend Senershield-R/-RS/-VB or SikaWall MaxFlash onto bottom of blocking or provide alternate air seal at sheathing termination to blocking.
- Reference *Acceptable Sealants for use with Senergy Wall Systems* Technical Bulletin for a list of sealants.

VNC-24 2401

(*NOTE: BY OTHERS)

The details within are the latest recommendations and are represented in good faith by Sika Corporation US (hereinafter Sika). The details are subject to change without notice. Sika accepts no liability for the end use of the details. For conditions not shown, consult Sika for review of specific details.

- Install Sika materials in accordance with current installation instructions.
- Unsatisfactory conditions shall be reported to the General Contractor and corrected before the application of Sika products.

Senerflex Vulcan NC System

SECTION AT FASCIA / SOFFIT

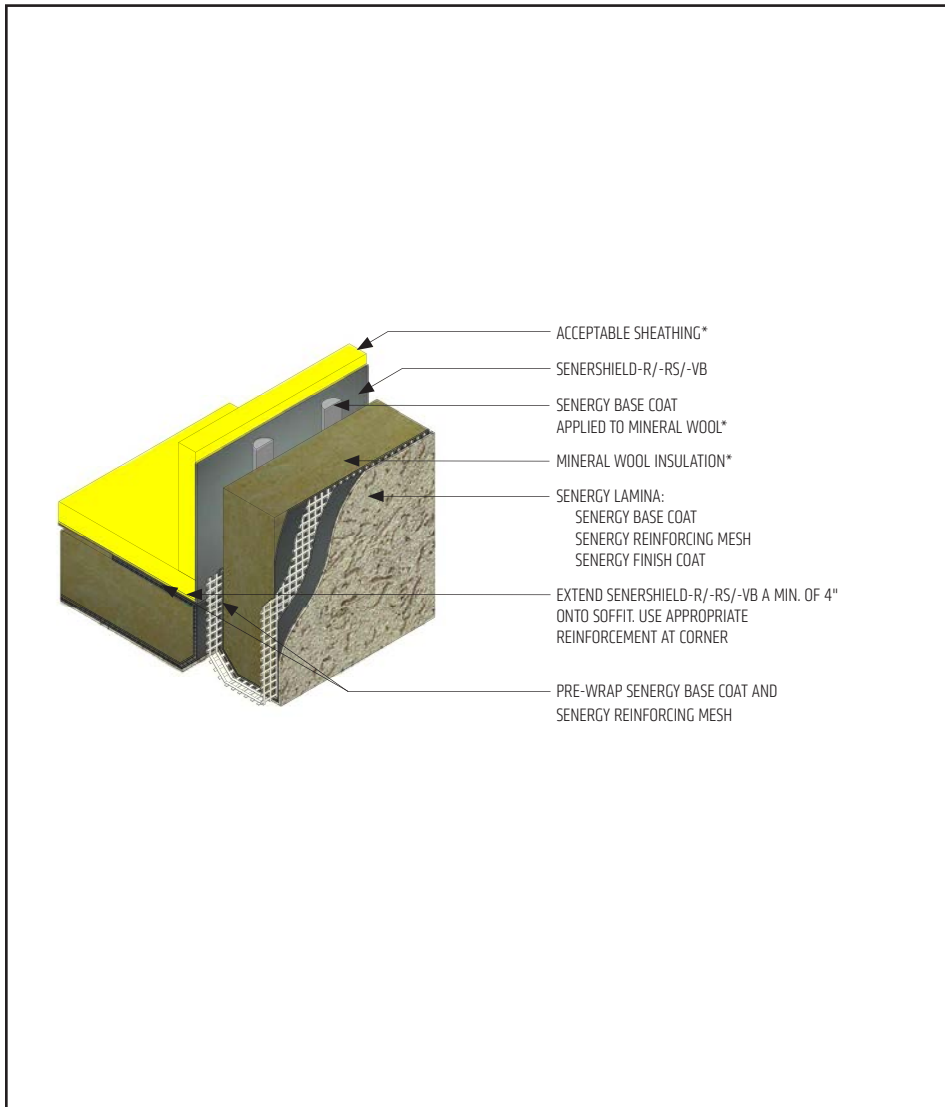

- All terminations must be fully encapsulated with mesh reinforced base coat. Pre-backwrapping is recommended at drainage terminations. Extend reinforcing mesh a minimum of 2 1/2" onto back of insulation board.
- Ensure a means for drainage is provided at system termination at soffit/ fascia transition.
- Extend Senershield-R/-RS/-VB a minimum of 4" (100mm) onto soffit. If necessary for air barrier continuity Senershield-R/-RS/-VB can be applied over the entire soffit.

VNC-25 2401

(*NOTE: BY OTHERS)

The details within are the latest recommendations and are represented in good faith by Sika Corporation US (hereinafter Sika). The details are subject to change without notice. Sika accepts no liability for the end use of the details. For conditions not shown, consult Sika for review of specific details.

- Install Sika materials in accordance with current installation instructions.
- Unsatisfactory conditions shall be reported to the General Contractor and corrected before the application of Sika products.

Senerflex Vulcan NC System

TYPICAL CORE MOUNTED RAILING ATTACHMENT

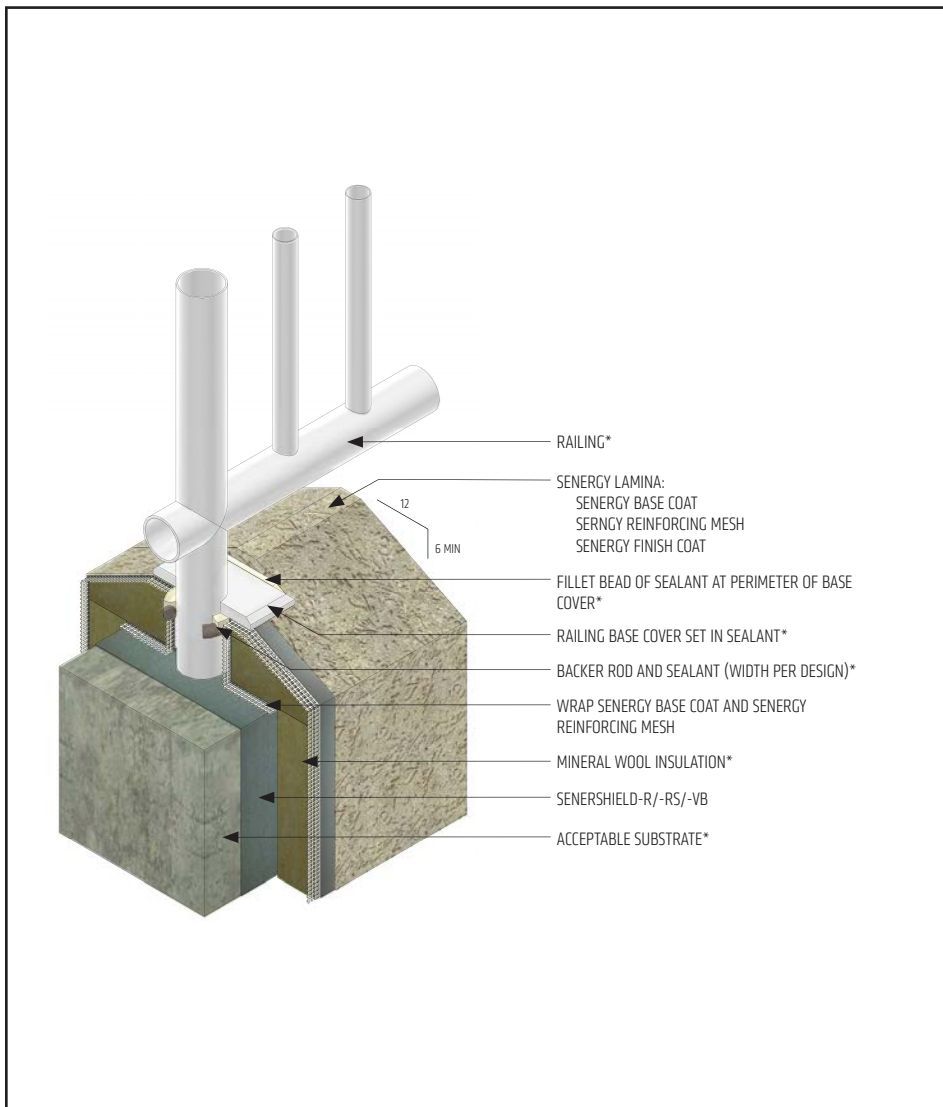

- All terminations must be fully encapsulated with mesh reinforced base coat. reinforcing mesh a minimum of 2 1/2" onto back of insulation board.
- Ensure all penetrations into the system are properly sealed.
- Reference *Acceptable Sealants for use with Senergy Wall Systems* Technical Bulletin for a list of sealants.

VNC-26 2401

(*NOTE: BY OTHERS)

The details within are the latest recommendations and are represented in good faith by Sika Corporation US (hereinafter Sika). The details are subject to change without notice. Sika accepts no liability for the end use of the details. For conditions not shown, consult Sika for review of specific details.

- Install Sika materials in accordance with current installation instructions.
- Unsatisfactory conditions shall be reported to the General Contractor and corrected before the application of Sika products.

Senerflex Vulcan NC System

TYPICAL RAILING ATTACHMENT

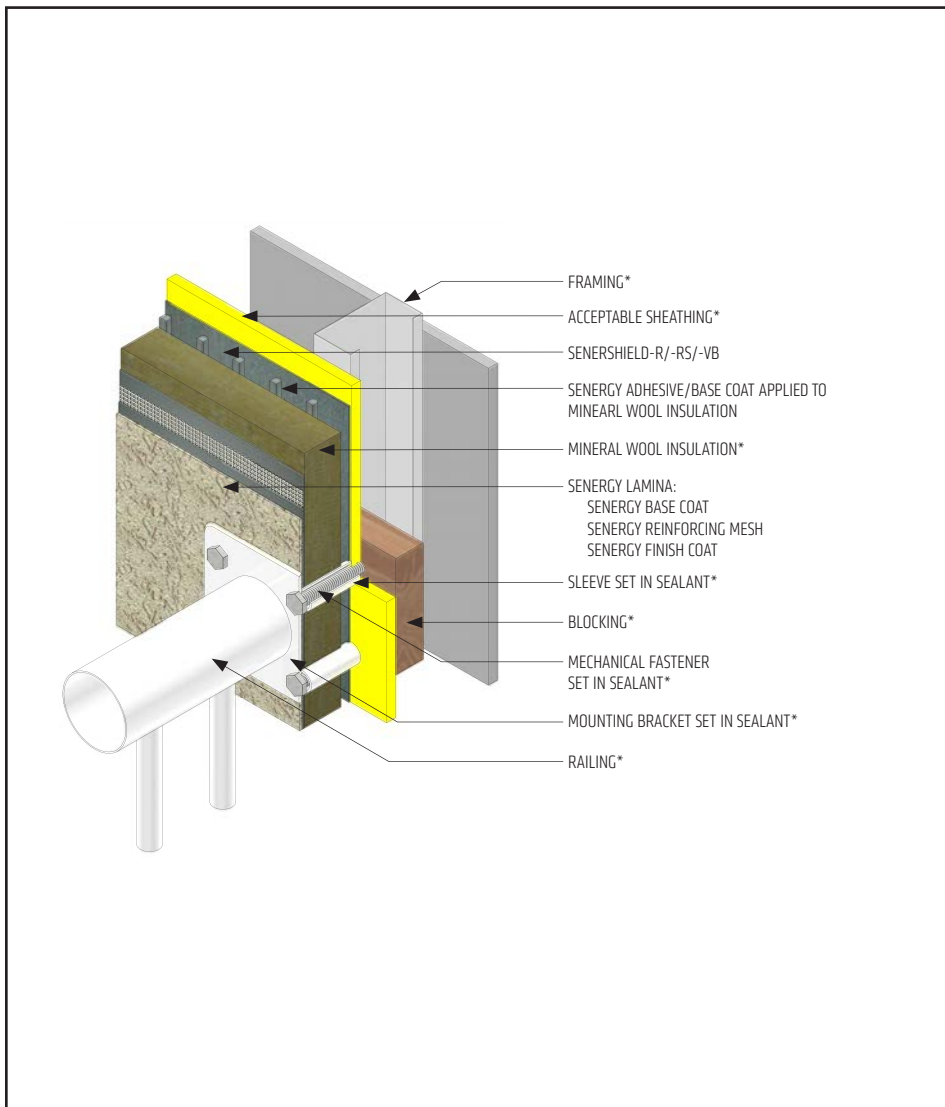

- All terminations must be fully encapsulated with mesh reinforced base coat.
- Ensure all penetrations into the system are properly sealed.
- Reference *Acceptable Sealants for use with Senergy Wall Systems* Technical Bulletin for a list of sealants.

VNC-27 2401

(*NOTE: BY OTHERS)

The details within are the latest recommendations and are represented in good faith by Sika Corporation US (hereinafter Sika). The details are subject to change without notice. Sika accepts no liability for the end use of the details. For conditions not shown, consult Sika for review of specific details.

- Install Sika materials in accordance with current installation instructions.
- Unsatisfactory conditions shall be reported to the General Contractor and corrected before the application of Sika products.

Senerflex Vulcan NC System

TYPICAL SIGN ATTACHMENT

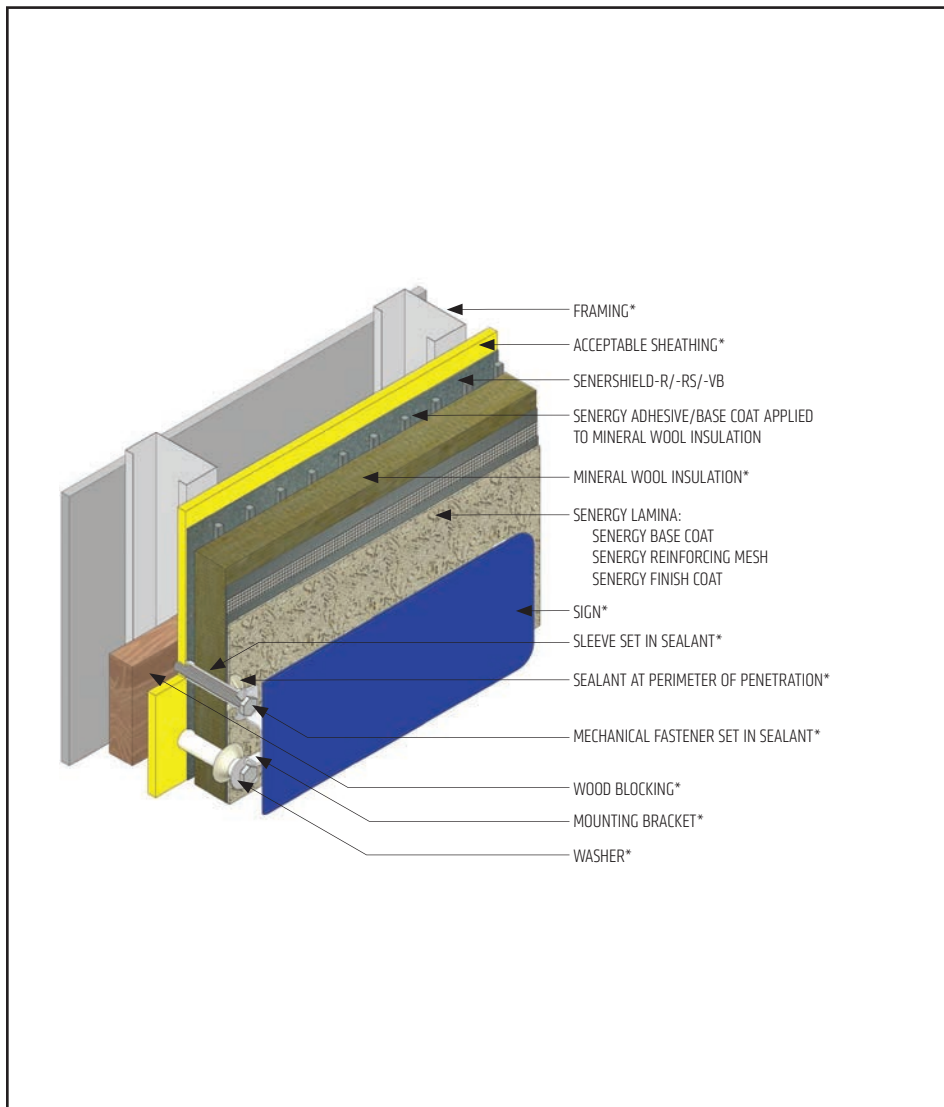

- All terminations must be fully encapsulated with mesh reinforced base coat.
- Ensure all penetrations into the system are properly sealed.
- Blocking or other structural support required for sign attachment is by others.

VNC-28 2401

(*NOTE: BY OTHERS)

The details within are the latest recommendations and are represented in good faith by Sika Corporation US (hereinafter Sika). The details are subject to change without notice. Sika accepts no liability for the end use of the details. For conditions not shown, consult Sika for review of specific details.

- Install Sika materials in accordance with current installation instructions.
- Unsatisfactory conditions shall be reported to the General Contractor and corrected before the application of Sika products.



LIMITED WARRANTY NOTICE

Prior to each use of any product of Sika Corporation, its subsidiaries or affiliates ("SIKA"), the user must always read and follow the warnings and instructions on the product's most current product label, Product Data Sheet and Safety Data Sheet which are available at usa.sika.com/senenergy or by calling our Technical Service Department at +1 (800) 589-1336.

Nothing contained in any SIKA literature or materials relieves the user of the obligation to read and follow the warnings and instructions for each SIKA product as set forth in the current product label, Product Data Sheet and Safety Data Sheet prior to use of the SIKA product.

SIKA warrants this product for one year from date of installation to be free from manufacturing defects and to meet the technical properties on the current Product Data Sheet if used as directed within the product's shelf life. User determines suitability of product for intended use and assumes all risks. User's and/or buyer's sole remedy shall be limited to the purchase price or replacement of this product exclusive of any labor costs. NO OTHER WARRANTIES EXPRESS OR IMPLIED SHALL APPLY INCLUDING ANY WARRANTY OF MERCHANTABILITY OR FITNESS FOR A PARTICULAR PURPOSE. SIKA SHALL NOT BE LIABLE UNDER ANY LEGAL THEORY FOR SPECIAL OR CONSEQUENTIAL DAMAGES. SIKA SHALL NOT BE RESPONSIBLE FOR THE USE OF THIS PRODUCT IN A MANNER TO INFRINGE ON ANY PATENT OR ANY OTHER INTELLECTUAL PROPERTY RIGHTS HELD BY OTHERS. Sale of SIKA products are subject to the Terms and Conditions of Sale which are available at usa.sika.com.

For the most current version of this literature, please visit our website at usa.sika.com/senergy.

Sika Corporation

201 Polito Avenue
Lyndhurst, NJ 07071 USA
Customer Service +1 (800) 433-9517
Technical Service +1 (800) 589-1336
usa.sika.com/senergy

Rev April 2024

BUILDING TRUST

