

Finestone Surfacing System for Insulated Concrete Forms (ICFs)

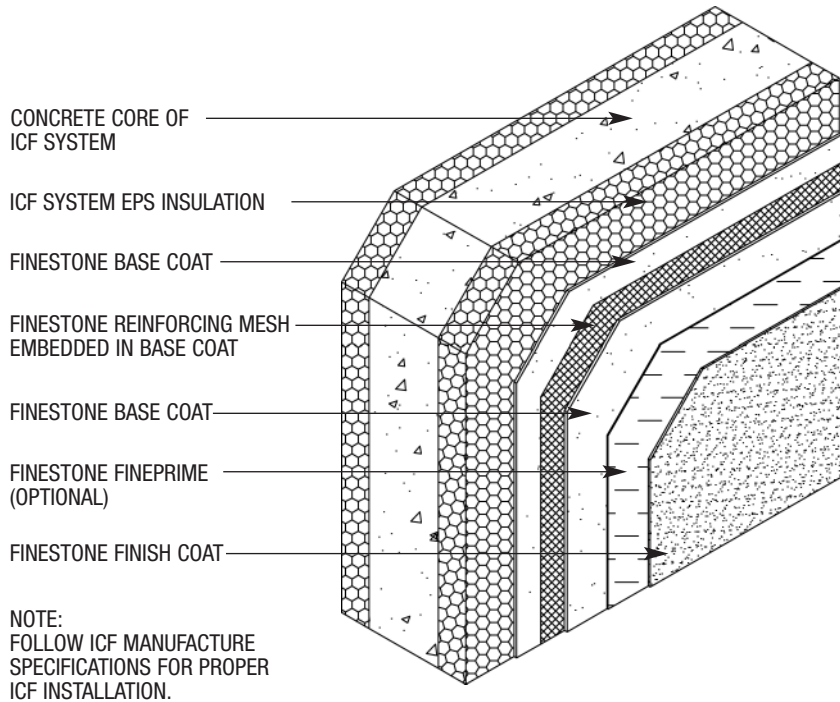

1. Finestone ICF Surfacing System Installation
2. ICF System Installation with Optional Additional Layer of EPS over ICF
3. Reveal
4. EPS Shape Application
5. Window Head (Wood Buck)
6. Window Jamb (Wood Buck)
7. Window Head (Vinyl Buck with EPS Trim)
8. Window Jamb (Vinyl Buck with EPS Trim)
9. Recessed Window Head/Jamb (Wood Buck/Vinyl Buck)
10. Window Sill (Wood Buck with EPS Trim)
11. Window Sill (Vinyl Buck with EPS Trim)
12. Recessed Window Sill (Wood Buck/VINYL BUCK)
13. Parapet
14. Transition to Existing Wall
15. Penetration
16. Termination at Foundation
17. Floorline (Non-Combustible Construction)
18. Eave Detail Exposed Top Plate
19. Sloped Roof/Wall Intersection
20. Kick-out Flashing



ICF-01 TYPICAL FINESTONE ICF SURFACING SYSTEM INSTALLATION

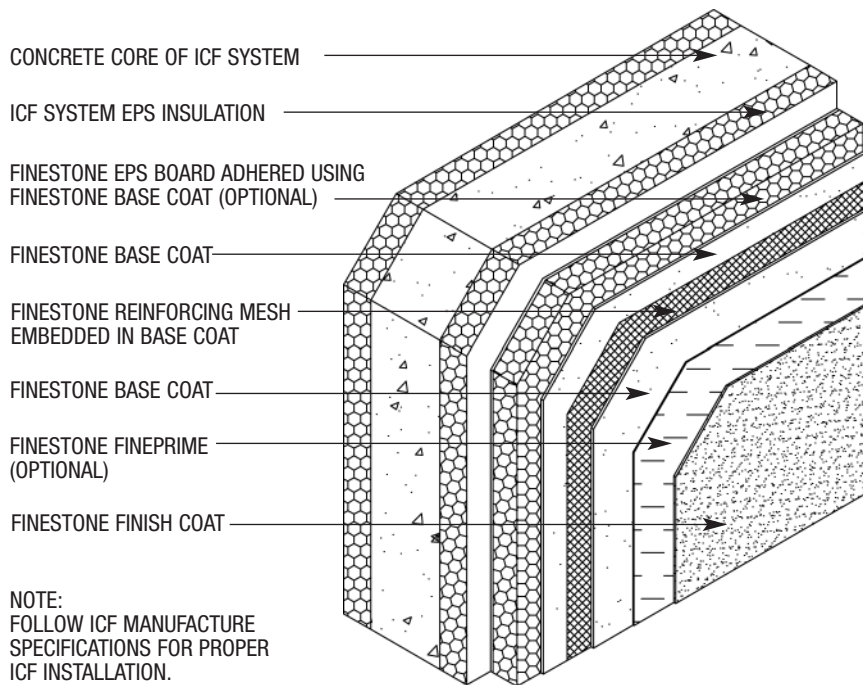

ICF-02 TYPICAL FINESTONE ICF SURFACING SYSTEM INSTALLATION WITH OPTIONAL ADDITIONAL LAYER OF EPS OVER ICF

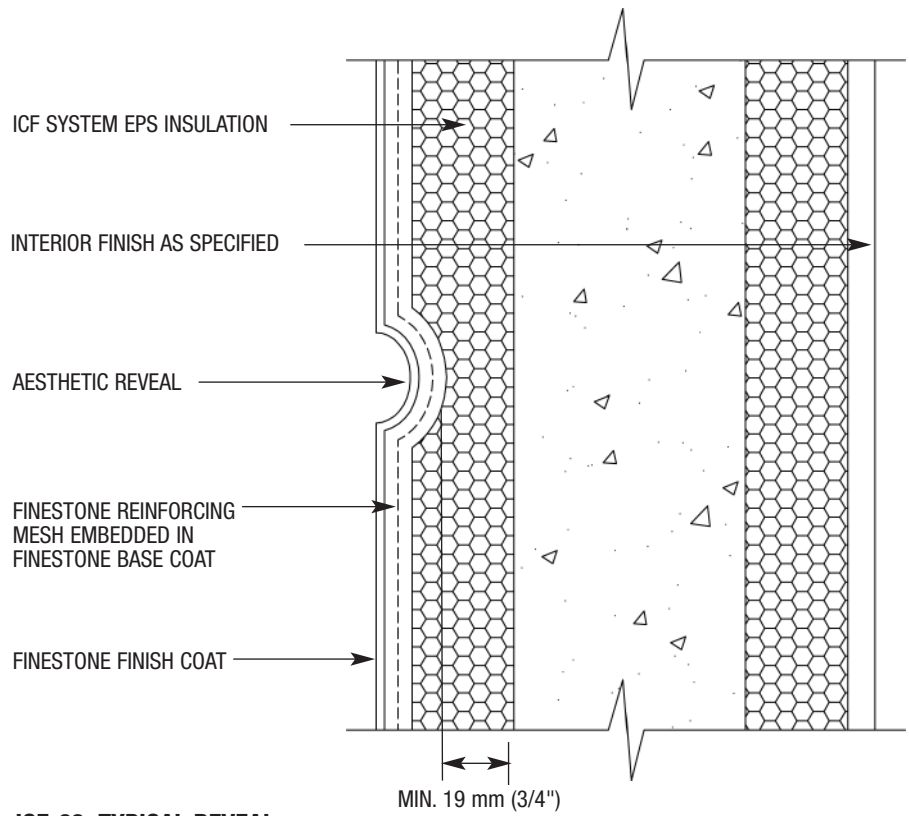

ICF-03 TYPICAL REVEAL

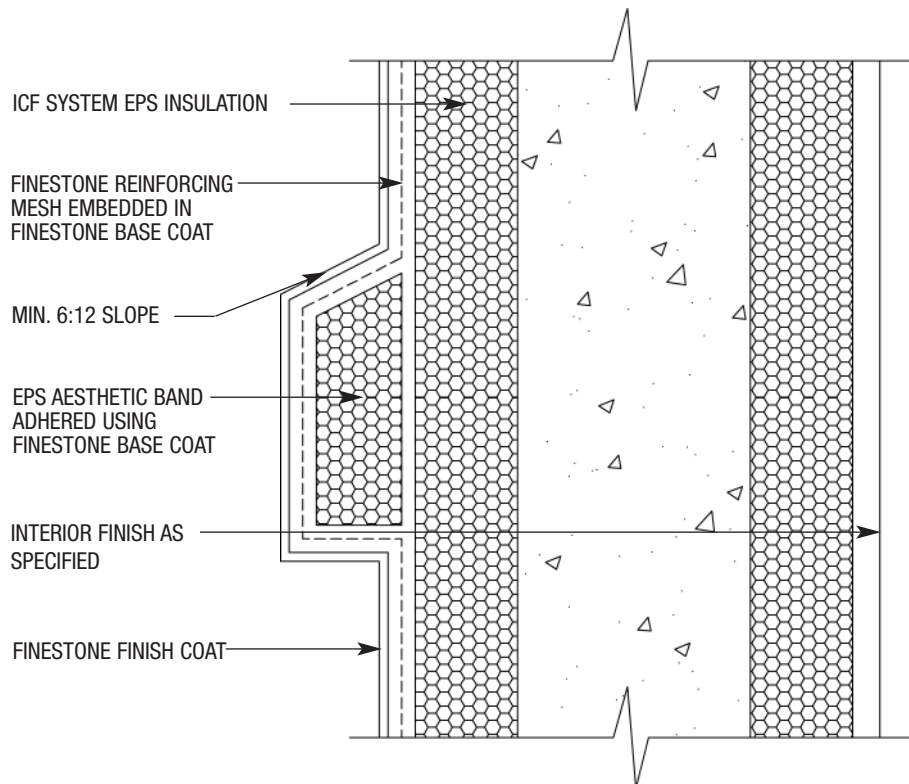

ICF-04 TYPICAL EPS SHAPE APPLICATION

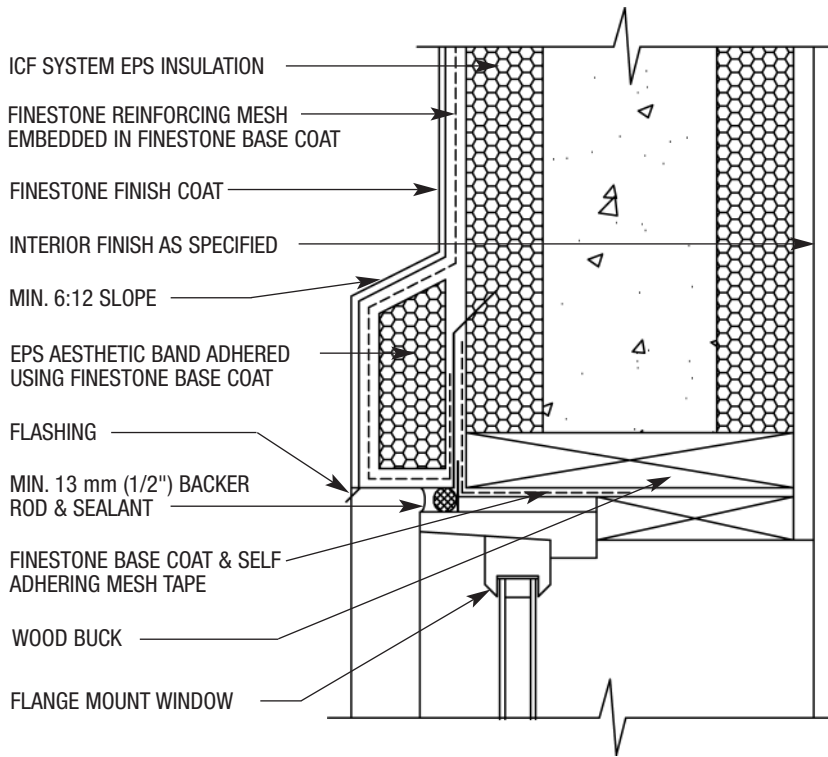

ICF-05 TYPICAL WINDOW HEAD DETAIL (WOOD BUCK)

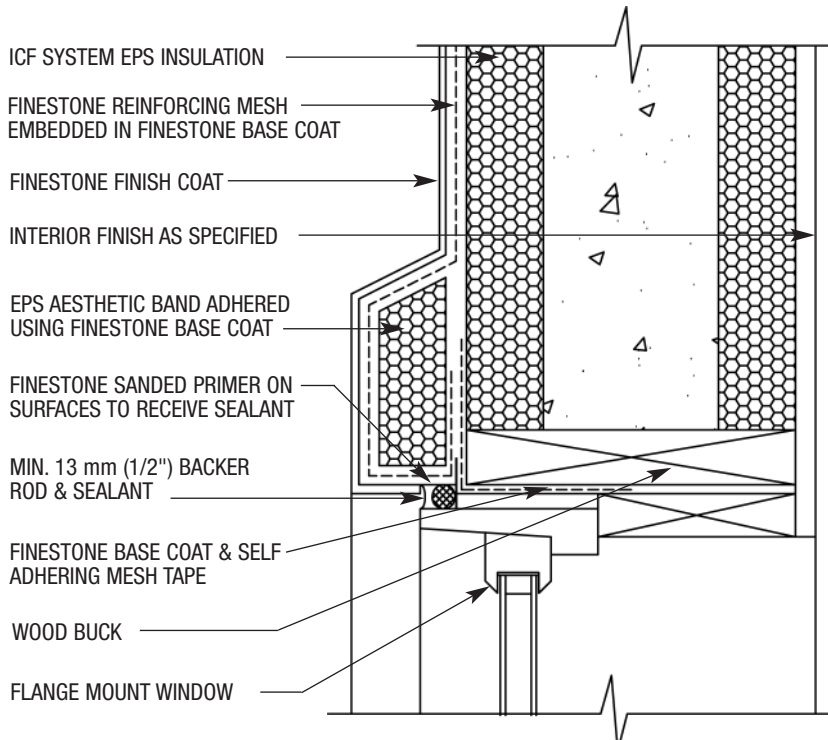

ICF-06 TYPICAL WINDOW JAMB DETAIL (WOOD BUCK)

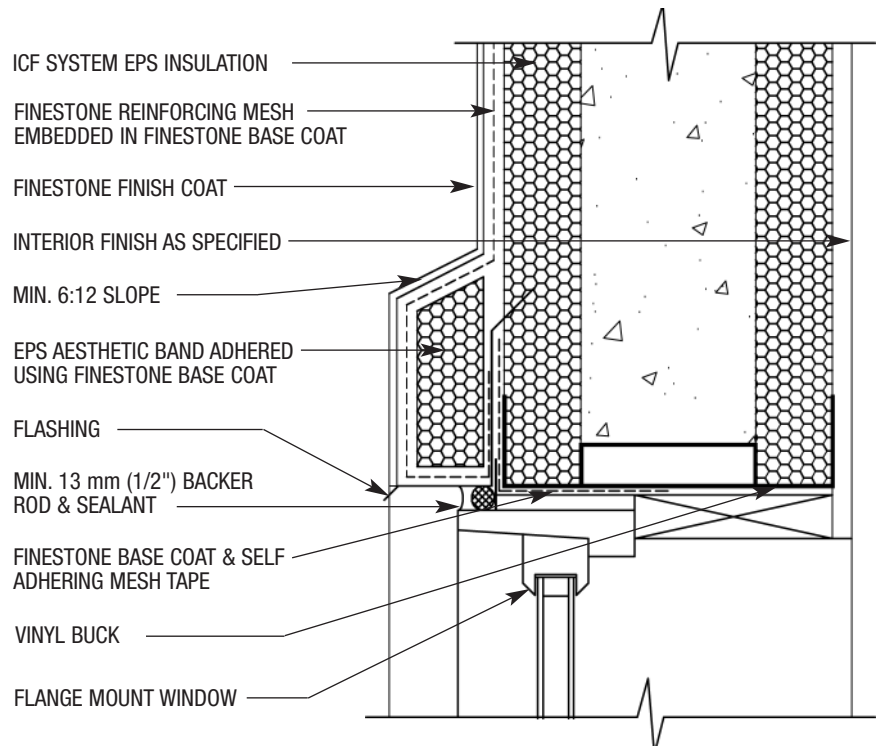

ICF-07 WINDOW HEAD (VINYL BUCK WITH EPS TRIM)

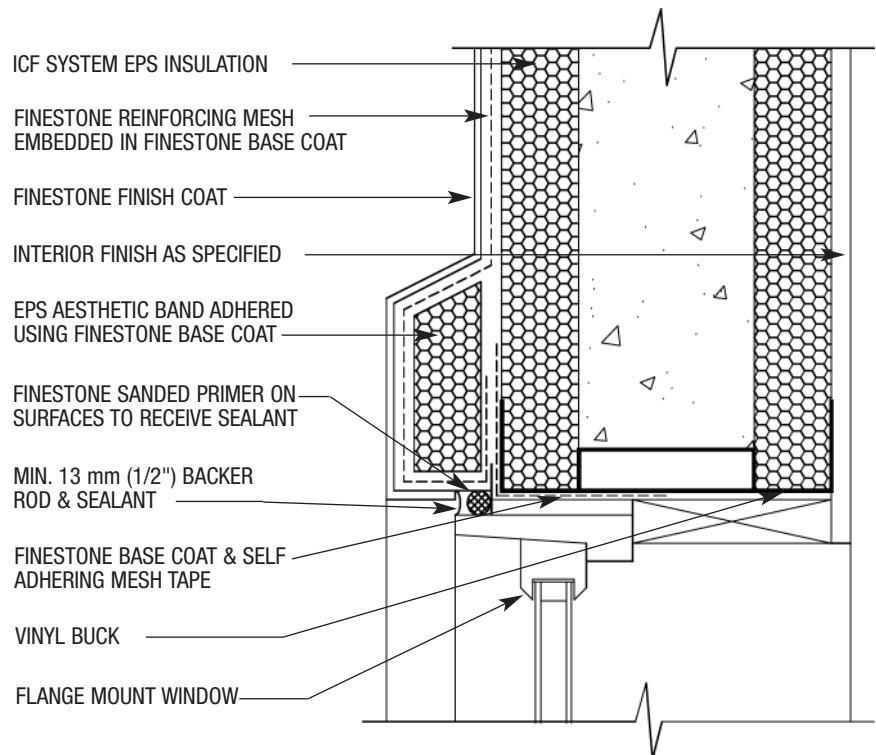

ICF-08 WINDOW JAMB (VINYL BUCK WITH EPS TRIM)

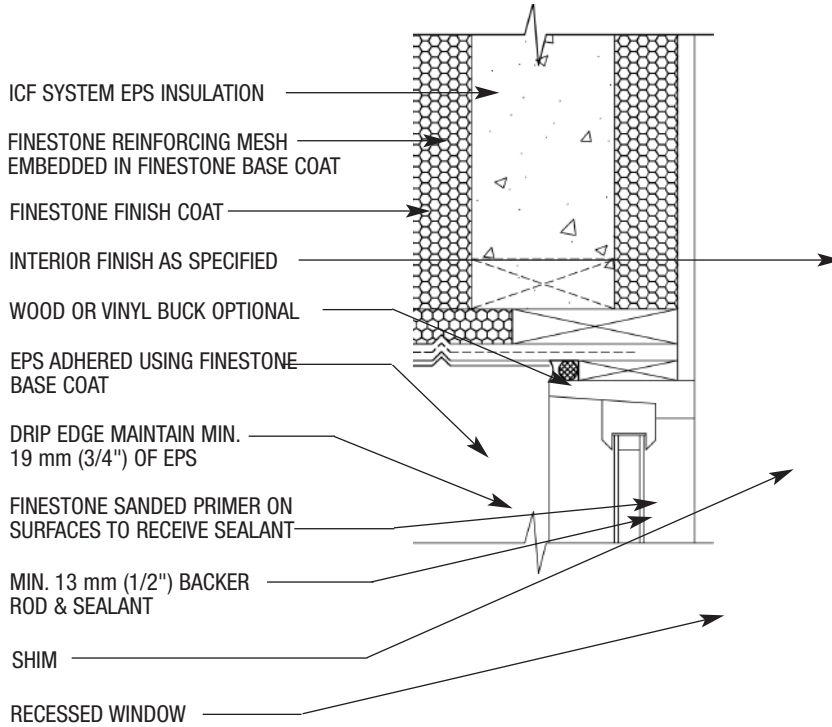

ICF-09 RECESSED WINDOW HEAD/JAMB (WOOD BUCK/VINYL BUCK)

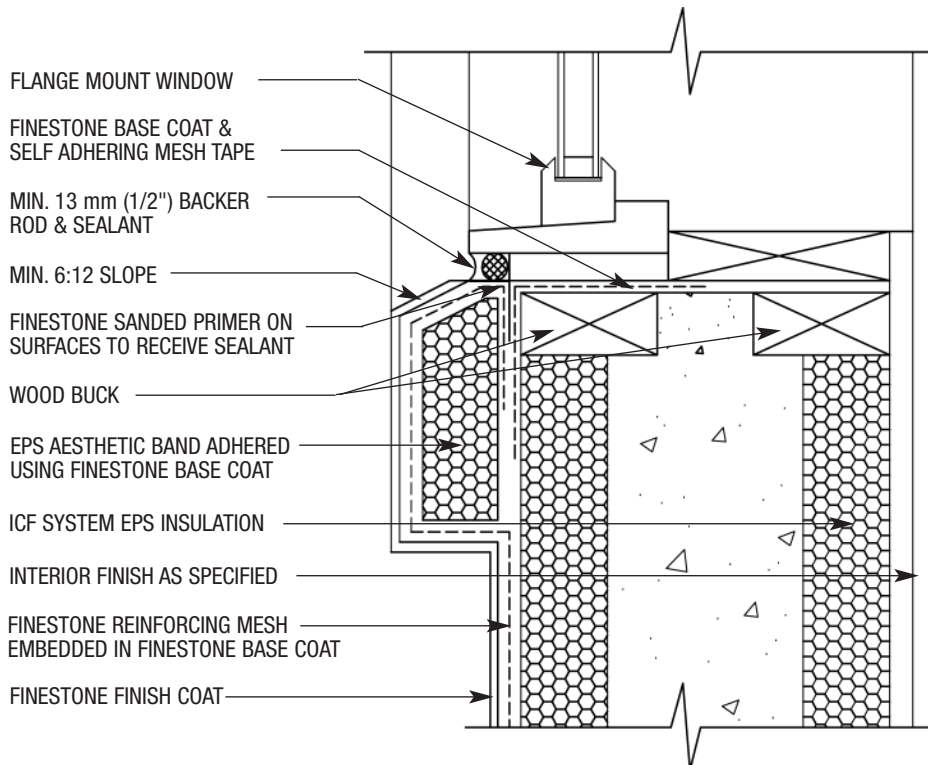

ICF-10 WINDOW SILL (WOOD BUCK WITH EPS TRIM)

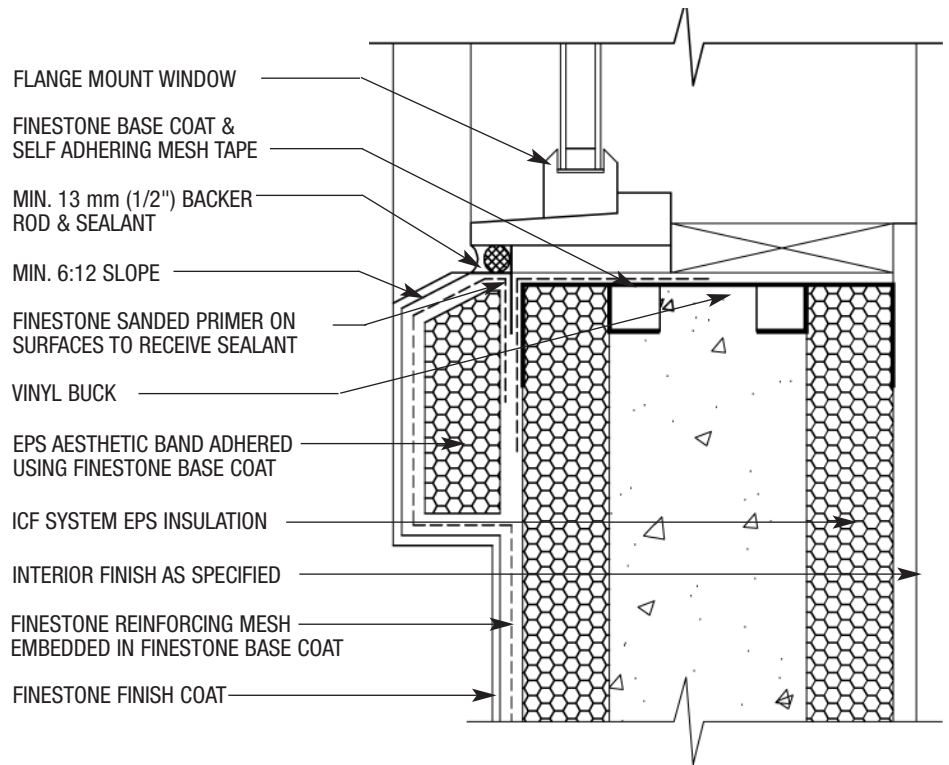

ICF-11 WINDOW SILL (VINYL BUCK WITH EPS TRIM)

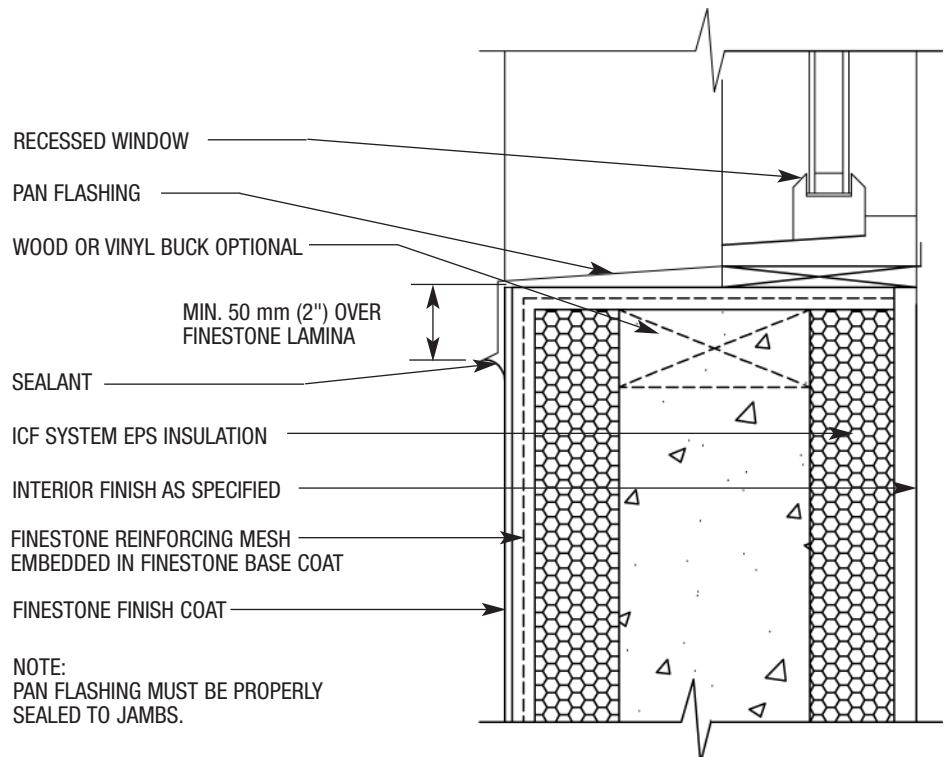

ICF-12 RECESSED WINDOW SILL (WOOD BUCK/VINYL BUCK)

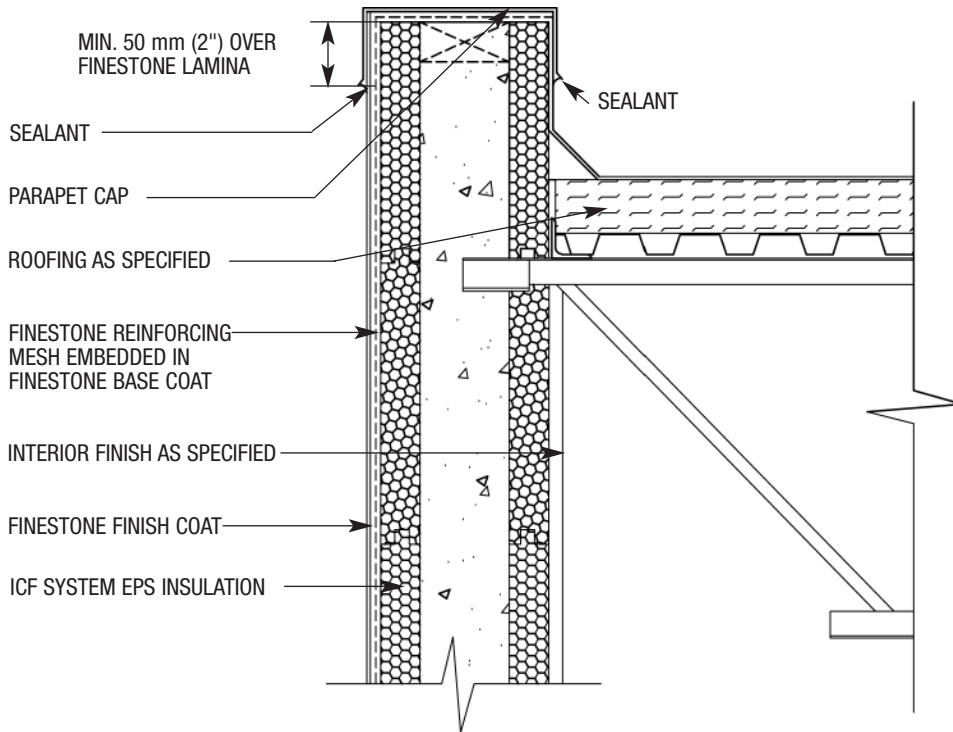

ICF-13 TYPICAL PARAPET DETAIL

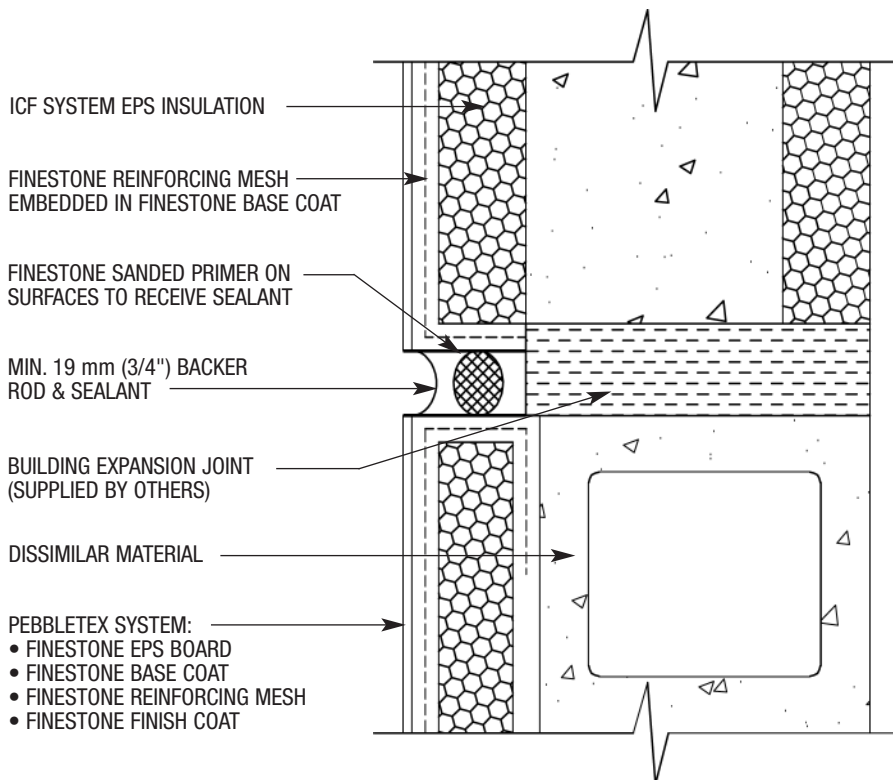

ICF-14 TYPICAL TRANSITION TO EXISTING WALL

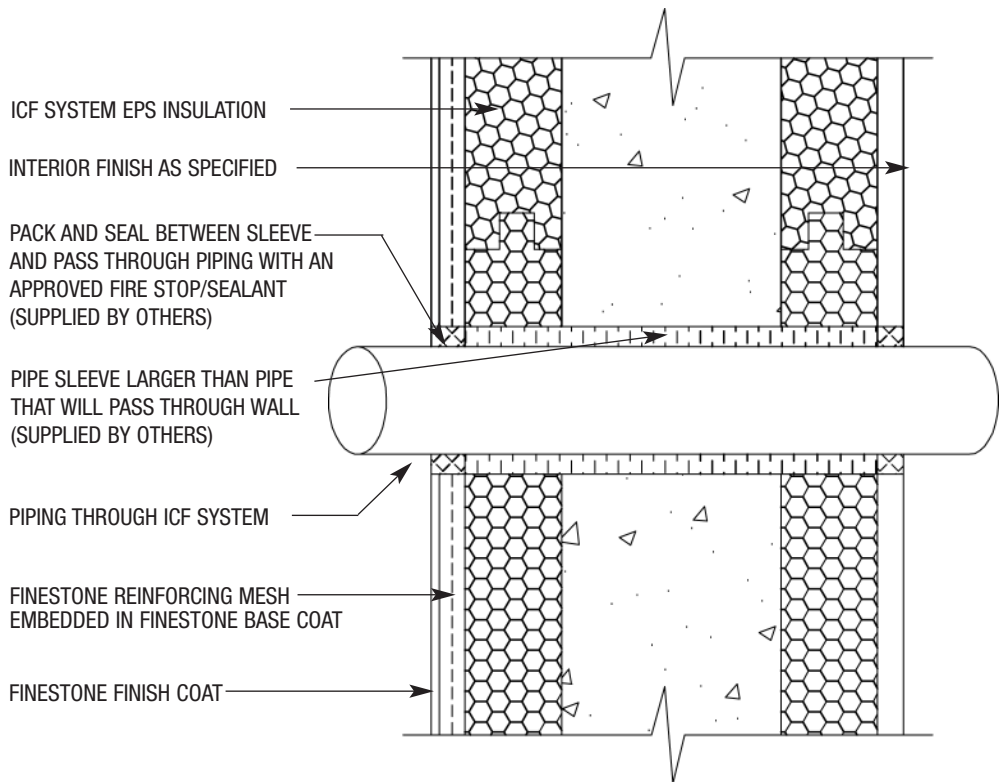

ICF-15 TYPICAL PENETRATION

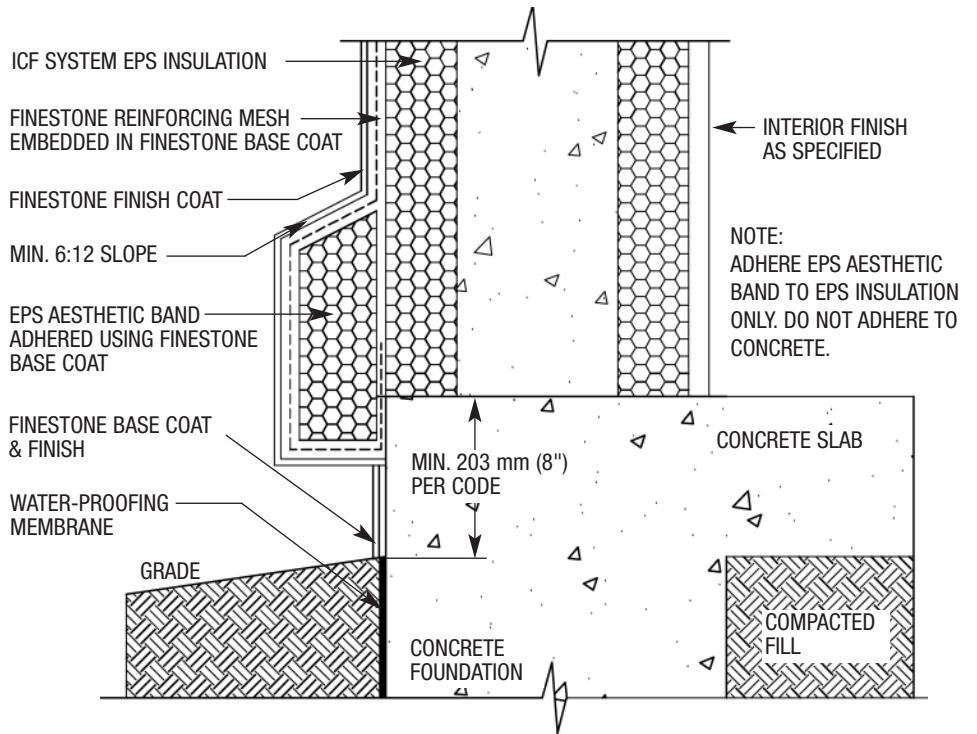

ICF-16 TYPICAL TERMINATION AT FOUNDATION

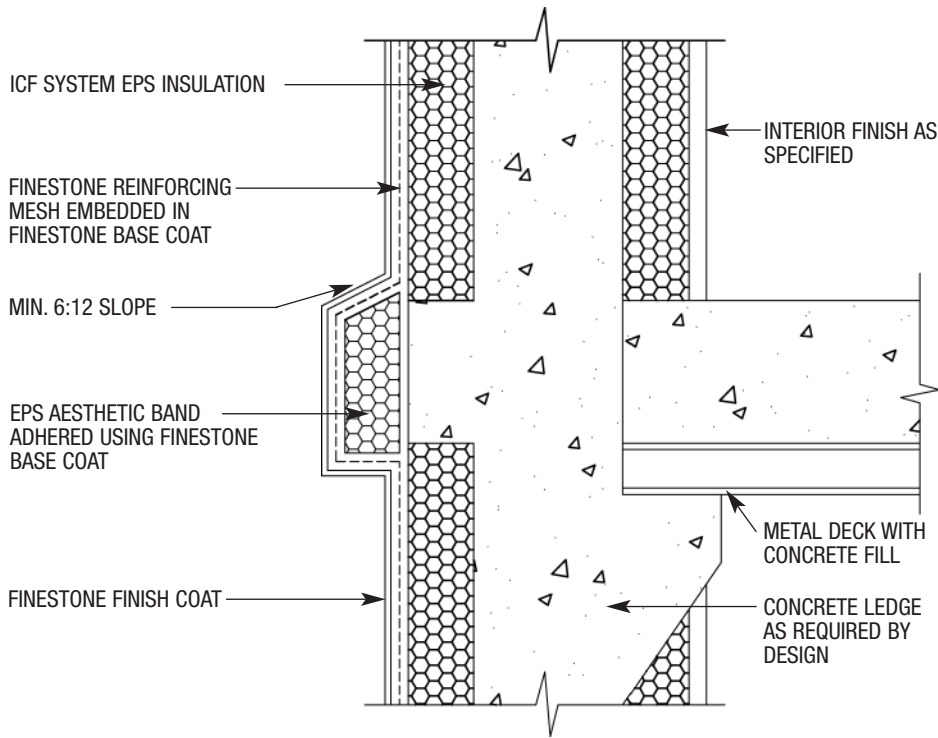

ICF-17 FLOORLINE (NON-COMBUSTIBLE CONSTRUCTION)

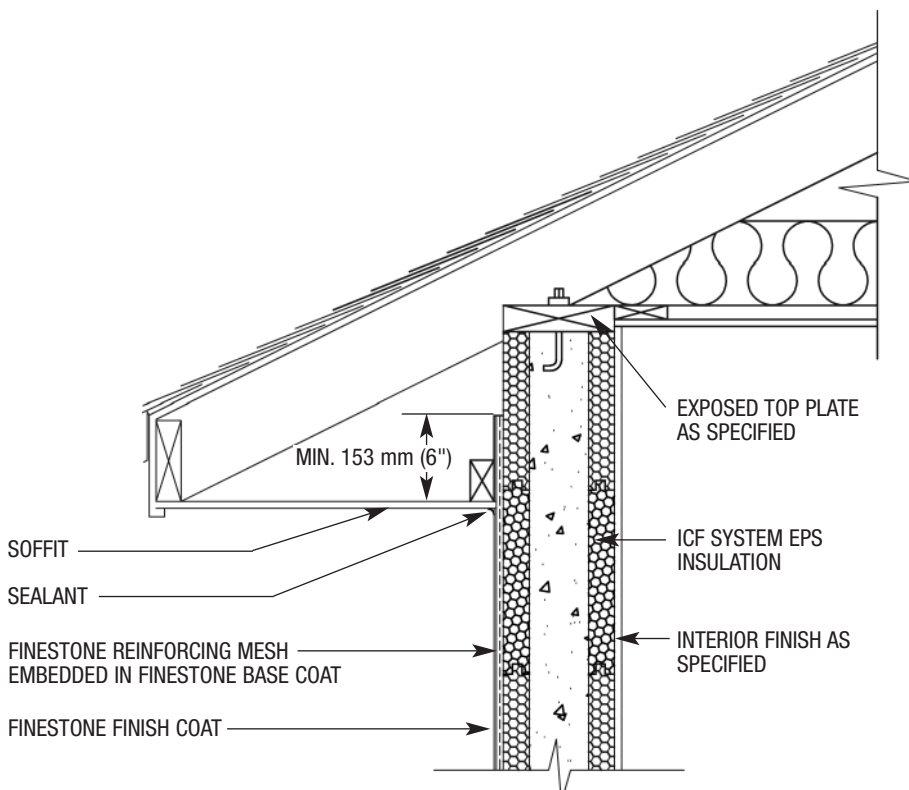

ICF-18 EAVE DETAIL EXPOSED TOP PLATE

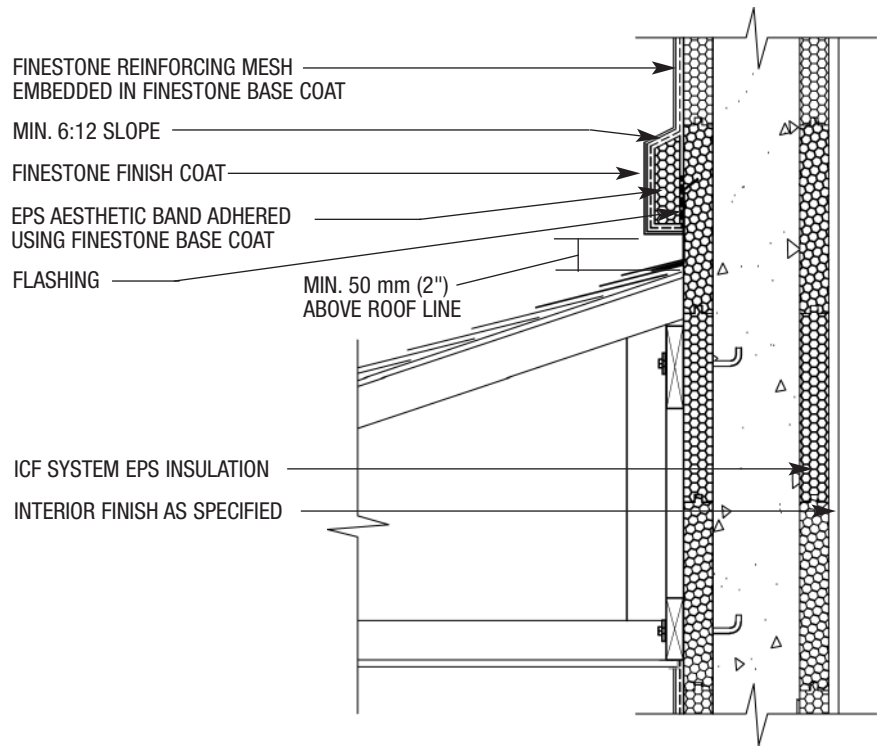

ICF-19 SLOPED ROOF/WALL INTERSECTION

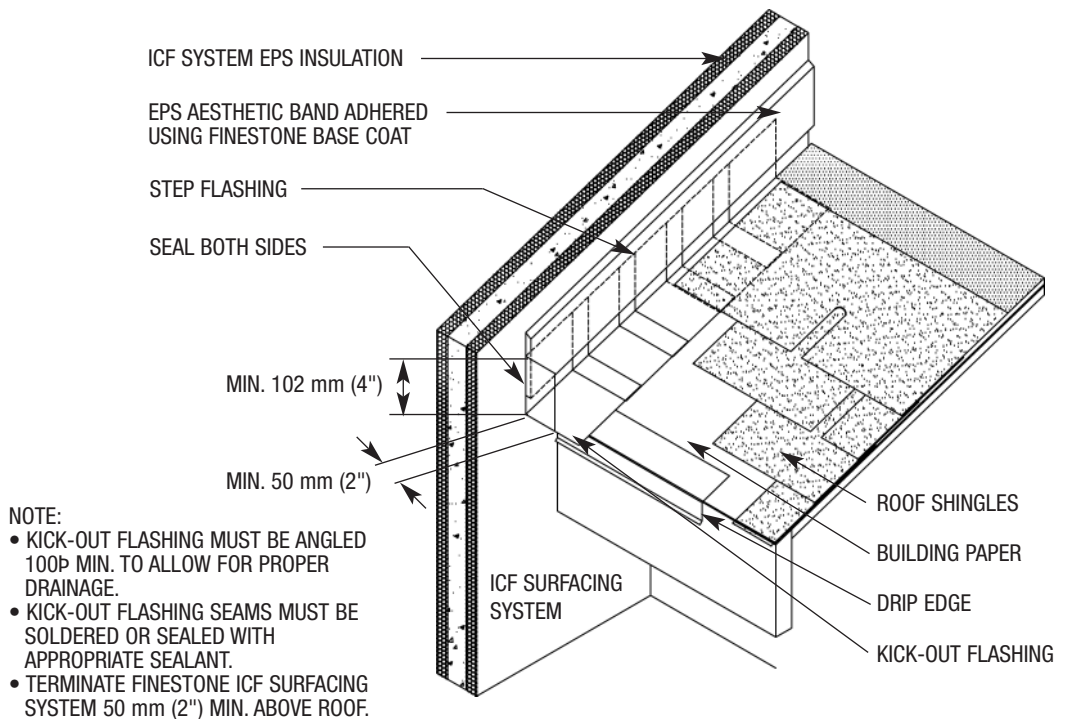

ICF-20 TYPICAL KICK-OUT FLASHING DETAIL

Technical Support

Consult our Technical Services Department (1-800-221-9255) for specific recommendations concerning all other applications.

Note:

BASF Wall Systems is an operating unit of BASF Corporation (herein after referred to as "BASF Wall Systems")

These details represent BASF Wall Systems' latest recommendations. They are presented in good faith by BASF Wall Systems. These details are subject to change without notice. BASF Wall Systems accepts no liability for the end use of these details. For conditions not shown, consult BASF Wall Systems for review of specific details.

Disclaimer

This information and all further technical advice are based on BASF's present knowledge and experience. However, BASF assumes no liability for providing such information and advice including the extent to which such information and advice may relate to existing third party intellectual property rights, especially patent rights. In particular, BASF disclaims all CONDITIONS AND WARRANTIES, WHETHER EXPRESS OR IMPLIED, INCLUDING THE IMPLIED WARRANTIES OF FITNESS FOR A PARTICULAR PURPOSE OR MERCHANTABILITY. BASF SHALL NOT BE RESPONSIBLE FOR CONSEQUENTIAL, INDIRECT OR INCIDENTAL DAMAGES (INCLUDING LOSS OF PROFITS) OF ANY KIND. BASF reserves the right to make any changes according to technological progress or further developments. It is the customer's responsibility and obligation to carefully inspect and test any incoming goods. Performance of the product(s) described herein should be verified by testing and carried out only by qualified experts. It is the sole responsibility of the customer to carry out and arrange for any such testing. Reference to trade names used by other companies is neither a recommendation, nor an endorsement of any product and does not imply that similar products could not be used.

Residential Policy

Apply wall systems in accordance with local building codes in force at the time of construction. On one and two-family residential framed construction, BASF Wall Systems requires that the wall system selected be one that includes provisions for moisture drainage. Please view the *Finestone Residential Policy Bulletin* on the Finestone website for a more detailed discussion of this topic.

BASF Wall Systems

3550 St. Johns Bluff Road South
Jacksonville, FL 32224-2614
Phone 800 • 221 • 9255
Fax 904 • 996 • 6300
www.finestone.basf.com