

MasterSeal[®] 951

TPO metal termination strip

DESCRIPTION

Finishing element for TPO membrane. Zinc steel termination strip coated on the surface with TPO membrane resistant to weathering and ultraviolet rays.

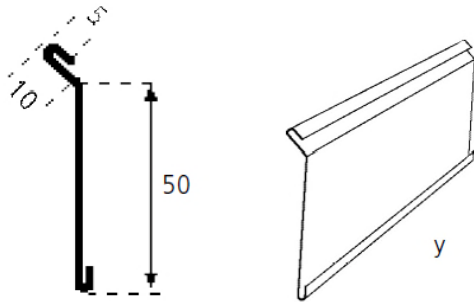

QUALITY AND CARE

All products originating from Master Builders Solutions Dubai, UAE facility are manufactured under a management system independently certified to conform to the requirements of the quality, environmental and occupational Health & Safety standards ISO 9001 and ISO 14001.

* Properties listed are based on laboratory controlled tests.

® = Registered trademark of the MBCC Group in many countries.

PRIMARY USE

MasterSeal 951 is designed to be used as an accessory for termination and fixing element in the TPO membranes waterproofing systems from Master Builders Solutions.

PACKAGING

MasterSeal 951 is supplied in a packing of 10 pc per box.

Thickness	1.8 mm
Length	2/3 m
Height	50 mm
Weight	0.39 kg/m
Colour	Sand Grey

TYPICAL PROPERTIES*

Puncture resistance DIN 16726-5.12	≥400 mm
Cold bending DIN 53361	≤ -35°C
Resistance to artificial weathering DIN 16726-5.17	No weathering

APPLICATION GUIDELINES

For application details, please refer to the TPO membrane system method statement / manual or contact Master Builders Solutions Technical Services department.

MasterSeal[®] 951

MBS_CC-UAE/SI_951_03_18/v1/

STATEMENT OF RESPONSIBILITY

The technical information and application advice given in this Master Builders Solutions publication are based on the present state of our best scientific and practical knowledge. As the information herein is of a general nature, no assumption can be made as to a product's suitability for a particular use or application and no warranty as to its accuracy, reliability or completeness either expressed or implied is given other than those required by law. The user is responsible for checking the suitability of products for their intended use.

NOTE

Field service where provided does not constitute supervisory responsibility. Suggestions made by Master Builders Solutions either orally or in writing may be followed, modified or rejected by the owner, engineer or contractor since they, and not Master Builders Solutions, are responsible for carrying out procedures appropriate to a specific application.

**Master Builders Solutions
Construction Chemicals LLC**
P.O. Box 37127, Dubai, UAE
Tel: +971 4 8090800
www.master-builders-solutions.com/en-ae

Disclaimer: the TUV mark relates to certified management system and not to the product mentioned on this datasheet



A brand of
MBCC GROUP